

**REPORT OF THE
DEPARTMENT OF EDUCATION ON**

**Safety of School
Playground
Equipment**

**TO THE GOVERNOR AND
THE GENERAL ASSEMBLY OF VIRGINIA**



HOUSE DOCUMENT NO. 26

**COMMONWEALTH OF VIRGINIA
RICHMOND
1992**

Preface

During the 1991 General Assembly session, Delegate Mary T. Christian proposed a study on the safety of school playgrounds and equipment. The purpose of the study was to determine if a need exists for statewide standards to ensure the safety of school playgrounds, the age appropriateness of playground equipment, and regulations or guidelines for the repair and replacement of broken and obsolete equipment. Resulting from Delegate Christian's proposal, the General Assembly passed House Joint Resolution 473 requesting the Department of Education to conduct such a study (See Appendix A) .

In response to House Joint Resolution 473, on April 10, 1991, the Department of Education Management Team issued Request for Proposal (RFP) 91-29, Safety of School Playground Equipment (See Appendix B). The Division of Early Childhood Education responded with a proposal which was approved and awarded on May 8, 1991 (See Appendix C). The accepted proposal included the following study team membership:

Valerie Barrett - Associate Specialist, Gifted Programs	Team Leader
Jim Firebaugh - Principal Specialist, Science	
Elaine Grainger - Associate Specialist, Educational Measurement	
Charles Hamm - Associate Specialist, Health & Physical Education	
Jaye Harvey - Associate Specialist, Early Childhood Special Education	
Vijay Ramnarain - Architectural Consultant	

Special acknowledgement is given to other individuals who made valuable contributions to this study. In particular, the team wishes to recognize Liz Campbell, Program Development Supervisor, with the Department of Social Services, Division of Licensing Programs and Jeanne Sanders, Coordinator of the Central Virginia Childhood Injury Prevention Program, Medical College of Virginia, for their input. Also recognized are those individuals in school divisions throughout the Commonwealth who completed the surveys that were used in this study.

From the work of the team, it has been found that increased interest for playground safety exists at the national, state and local levels. Federal guidelines exist, as manifested in *A Handbook for Public Playground Safety, Volumes I and II*, published by the United States Consumer Product Safety Commission (USCPSC). In addition, independent organizations have developed guidelines and standards that influence the public sector. Moreover, as reported on surveys, the number, types and causes of playground accidents during the 1990-91 school year seem to indicate a need for more emphasis on playground safety.

Table of Contents

	Page
Preface	
Executive Summary	1
Introductory Chapter	5
Chapter I Types of Playground Equipment in Virginia's Public Schools	8
Chapter II Injuries Sustained on Public School Playgrounds in the Commonwealth	22
Chapter III Playground Safety Initiatives	25
Chapter IV Primary Manufacturers of Playground Equipment and Federal Standards	31
Chapter V School Division Recommendations Concerning Statewide Standards	34
Chapter VI Implications of Day Care Programs and Before and After School Child Care Licensing Requirements	36
Concluding Chapter	37
Appendices	39

Executive Summary

This study on the safety of school playgrounds was conducted by the Department of Education in response to House Joint Resolution 473, which was sponsored by Delegate Mary Christian. The purpose of this study was to determine whether there is a need for statewide standards to ensure the safety of school playgrounds, the age appropriateness of playground equipment, and the repair and replacement of broken or obsolete equipment.

Methodology

Information was gathered from school division personnel by means of two different surveys, a Division-wide Playground Safety Information Request and an Elementary School Playground Safety Information Request. Consultants, professional and parent organizations, manufacturers, and physical education directors from other states provided input into the review process. Literature searches and review of documents developed by public and private agencies provided additional information.

Types of Playground Equipment

Information concerning types of playground equipment was gathered from fifty-seven (57) elementary schools, using the Elementary School Playground Safety Information Request (See Appendix F). This survey revealed that the predominate types of playground equipment used on public school playgrounds are various types of climbing apparatus, sliding boards, swings, chinning bars, horizontal ladders, seesaws, fireman's poles, tire swings, trapezes, and merry-go-rounds.

Based on the study of information reviewed relative to types of playground equipment, it seems that a variety of equipment can be appropriate for the various student age groups in the elementary schools, if the equipment reflects the physical dimensions of the age group for which it is being installed. It appears that the inclusion of some types of equipment with certain age groups may provide greater opportunities for misuse (i.e. swings, slides, seesaws). It is recommended, therefore, that the school principal evaluate equipment carefully to determine if it meets the needs of students served at that particular school. Moreover, distinct playground areas for primary and upper elementary students should be established, and greater emphasis needs to be placed on the close supervision of all playground activities. It is important that those with responsibility for playground safety at the school building level ensure that appropriate resilient surfaces are in place under equipment and that these surfaces receive regular maintenance.

Injuries Sustained on Public School Playgrounds

A review of the results of the Division-wide Playground Safety Information Request provided information about the injuries sustained on public school playgrounds in the Commonwealth. Reporting procedures for playground injuries vary considerably in school divisions. It is difficult, therefore, to get an accurate account of rates and severity of injuries sustained across the Commonwealth. However, sixty-five (65) LEAs reported a total of 5,700 injuries during the 1990-91 school year. Based on LEA reports, of the 348,976 students enrolled in schools which have playgrounds, 1.75% of the children in these schools sustained an injury requiring professional medical attention. This apparent high rate of injuries may be due to broad interpretation of the word "professional" in "professional medical attention" which was the wording used in the survey. It is assumed that attention by the school nurse for minor injuries was interpreted as "professional medical attention."

Abrasions, cuts and puncture wounds constituted 53% of all reported injuries for the 1990-91. The next largest category was strains or sprains which made up 14% of all injuries. Head injuries accounted for 13%, broken bones, 5%; eye injuries, 3%; and other injuries, 12%.

Playground Safety Initiatives

A review of playground safety initiatives in other states revealed that nine (9) states have guidelines for playground equipment and seven (7) states have guidelines for playground surfaces. The degree of development and detail of guidelines for playground equipment and surfaces varies considerably.

Letters were sent to several organizations requesting information concerning their support of playground safety initiatives, regulations or guidelines. None of the organizations responding indicated support for specific initiatives; however, all responding indicated concerns about the safety of playground equipment.

The publication Accreditation Criteria and Procedures of the National Academy of Early Childhood Programs, distributed by the National Association for the Education of Young Children, was reviewed for guidelines pertaining to playground safety. These guidelines should be considered if it is determined that statewide guidelines, standards or regulations should be established.

The National Safety Council has published extensive guidelines in its publication Safety First Checklist - The Site Inspection System for Playground Equipment. (See Appendix R). This publication would make an excellent resource in the possible development of statewide guidelines, standards or regulations for the

safety of playground equipment.

Primary Manufacturers of Playground Equipment

National standards exist on the federal level and from testing agencies. During the fall of 1991, the U. S. Consumer Product Safety Commission will be establishing revised playground safety guidelines, based on research presented in the COMSIS Corporation report, "Development of Human Factors Criteria for Playground Equipment Safety. The American Society of Testing Materials (ASTM) has set several technical standards for properties of materials used in the construction of playground equipment and resilient surfaces.

School Division Recommendations Concerning Statewide Standards

A review of the results from the surveys to elementary schools and school divisions indicated that the majority of those responding feel there is a need for uniform, research-based standards to ensure the safety of school playgrounds and equipment; the age appropriateness of such equipment; and/or the repair and replacement of broken and obsolete equipment.

Implications of Day Care Licensing Requirements

A revision of the minimum standards for licensed child care centers, before and after school child care programs, and child day care camps serving school age children was called for in House Bill 1035, which was passed by the 1990 General Assembly. Revisions resulting from this bill potentially have implications for public school facilities used for before and after school child care programs.

Study Team Recommendations

The purpose of this study was to determine if there is a need for statewide standards to ensure the safety of school playgrounds. Therefore, on the basis of all the information reviewed, the project team has these recommendations:

- Playground safety information packets should be produced and disseminated to all elementary schools. These packets should include the U. S. Consumer Product Safety Commission's video and standards.
- State guidelines, standards or regulations should be established. These guidelines should be based on the playground safety standards under development by the USCPSC. These standards are scheduled to be released during the fall of 1991. The standards also should correlate with the Department of Social Services standards established for

licensing day care and before and after school program facilities.

- Any standards, guidelines or regulations should include recommendations for establishing separate play areas, with appropriate playground equipment, for the various age groups that are housed at each school.
- Standard reporting forms and procedures for collecting information concerning playground injuries should be developed. This would provide accurate data regarding the extent of injuries on public school playgrounds.
- If state guidelines, standards, or regulations are established, financial assistance should be made available to school divisions in order to aide them in achieving compliance with the regulations, thereby reducing the risk of serious injury to Virginia school children.

Introductory Chapter

This study on the safety of school playgrounds was conducted by the Department of Education in response to House Joint Resolution 473, which was sponsored by Delegate Mary Christian. The purpose of this study was to determine whether there is a need for statewide standards to ensure the safety of school playgrounds, the age appropriateness of playground equipment, and the repair and replacement of broken or obsolete equipment.

Since May of 1991, a team of six individuals has utilized a variety of techniques and sources to obtain the information required for this study. Information was collected from school division personnel, consultants, professional and parent organizations, and manufacturers.

Three surveys were developed by the study team with input from Liz Campbell, Program Development Supervisor, Department of Social Services, Division of Licensing Programs, and Jeanne Sanders, Coordinator of the Central Virginia Childhood Injury Prevention Program, Medical College of Virginia. (See Appendix D). The first survey, Division-wide Playground Safety Information Request, was sent to all school division superintendents through Superintendents Memo No. 53, dated June 15, 1991. (See Appendix E). The primary purpose of this survey was to collect information concerning playground injuries sustained on school playgrounds in all school divisions throughout the Commonwealth. Questions also were asked regarding a need for standards to ensure the safety of school playground equipment. Seventy-five (75) school divisions responded to this survey.

On June 17, 1991, a second survey, Elementary School Playground Information Request, was distributed to principals of fifty-four (54) elementary schools around the Commonwealth. (See Appendix F). This survey addressed equipment concerns and repeated questions about a need for standards to ensure the safety of school playgrounds. Fifty-eight (58) elementary principals responded to this survey.

A third survey, State Guidelines for School Playground Equipment, was sent to physical education directors located in state education agencies in all fifty states. (See Appendix G). Through this survey, information was collected about the existence of playground safety standards in other states. Responses were received from thirty-three (33) states.

Several institutions and organizations which would have a vested interest in playground safety concerns were contacted for input into this study. In this endeavor, the following institutions and organizations were contacted:

- University of Virginia, Health Information Center
- Virginia Commonwealth University, School of Environmental Health and Safety
- Medical College of Virginia, Central Virginia Childhood Injury Prevention Program
- American Academy of Pediatrics
- American Society for Testing Materials
- American Alliance for Health, Physical Education, Recreation, and Dance
- National Association for the Education of Young Children
- Virginia Association for Elementary School Principals
- Virginia Congress of Parents and Teachers
- Local School Divisions

Several documents provided information which was needed for this study on the safety of school playgrounds in Virginia. An Educational Resources Information Center (ERIC) search was conducted in late May, 1991, and was reviewed for pertinent information relative to playground safety. (See Appendix H). In addition, a copy of the report on playground safety prepared for the U. S. Consumer Product Safety Commission by the COMSIS Corporation, was obtained and reviewed on the basis of questions relative to this study. The recommendations of the Virginia Physical Education City and County Supervisors' Committee on Playground Safety were reviewed by the team. (See Appendix I).

As acknowledged previously, valuable information was obtained from two consultants who met with members of the study team during two separate meetings. Jeanne Saunders met with the team on May 17, 1991. She shared with the team information about her work with playground assessment and provided the team with an outlined overview of a playground safety presentation that she has developed. During this meeting, Ms. Saunders alerted the team to a need for standardized injury surveillance forms and procedures.

On May 28, 1991, the team met with Liz Campbell (See Appendix J). During this meeting, the team was informed about the implications of House Bill 1035, which calls for a revision of the minimum standards for licensed day care centers, before school and after school child care programs, and child day care camps serving school age children. Ms. Campbell also showed the team a playground safety videotape produced by the U. S. Consumer Product Safety Commission.

On several occasions, team members spoke with officials with the U. S. Consumer Product Safety Commission. In particular, Mr. Ross Coeser provided the team with information about the status of revised guidelines that may be adopted by the U. S. Consumer Product Safety Commission during the fall of 1991. A copy of a videotape produced by this organization was obtained with Mr. Coeser's assistance.

The study team's review of the information collected from the above described resources provided the basis for this study. A more detailed description of the findings is included in the body chapters.

Chapter I

Types of Playground Equipment in Virginia's Public Schools

The project team, with the input and assistance of external consultants, designed a three-page survey targeted at individual elementary schools. The purpose of the survey was to gather information concerning the types of playground equipment in use in some public schools in Virginia.

As elementary schools have various grade levels represented (e. g. K-3, K-6, 3-5), it was necessary to make sure that a sample of several different organizational patterns was represented. It was decided that surveys would be sent to the fifty-four elementary schools which had been visited by Department of Education staff during the Spring of 1991. This random sample demonstrated an appropriate variation in the grade organization patterns.

The division-wide survey sent to superintendents contained a copy of the school-level survey. In some instances superintendents distributed the school level that survey to principals. Therefore, the Department received a greater number of school level surveys than had been distributed. There were fifty-seven (57) responses. Some of the surveys had individual items or sections incompletely recorded.

The information was compiled in four separate data recording matrices. These different records reflect the organizational pattern of surveyed schools. They were:

Schools with a predominant primary organization, generally Kindergarten through Second grade - 11 schools;

Schools with a no primary grades present - 11 schools;

Schools with a full spectrum of primary and upper elementary grades - 33 schools; and

Schools with an all special education student population - 2 schools.

This was done to determine if patterns of equipment present showed any differences. These differences were not subjected to statistical analysis.

A compilation of the survey results is included in the following sections.

Also included is a brief description of the equipment, its use, and safety and age considerations. This information is derived from the research report "Development of Human Factors Criteria for Playground Equipment Safety" prepared for the U. S. Consumer Product Safety Commission by the COMSIS Corporation.

Climbing Apparatus

Survey Results

For the purpose of this study, many of the separately identifiable climbing structures frequently aggregated with this group were examined as distinct categories. Other equipment involving climbing, balancing, and hanging skills were considered separately. These were items such as chinning bars, overhead horizontal ladders, and firemen's poles (sliding poles). With the array of items listed on the surveys and options to describe additional equipment not listed, it was assumed by the project team that school principals would be able to describe and inventory their equipment accurately without lengthy descriptions on the survey. Additionally it is assumed that the intent of the categories was readily understandable, as multi-use climbing structures come in a vastly different configurations.

As a category, the various kinds of climbing apparatus were the most common type of playground equipment found at schools responding to the survey. This equipment was present at forty-nine (49) of fifty-seven (57) schools. Primary schools were the most likely to have some type of climbing structure. Of the eleven (11) schools in the primary category, all had at least one such structure on site.

More than half of the elementary schools without a primary grade component (upper elementary) had this type of equipment. Of these schools seven (7) of the twelve (12) surveyed had a climbing structure.

Of the thirty-three (33) schools with both primary and upper elementary grades, thirty (30) indicated they had some form of climbing apparatus. Of these 30 sites, 13 schools indicated that the climbing structure(s) on the playground were undifferentiated as to the specific grade level use. Sixteen (16) schools had climbing structures that were targeted specifically for either primary or upper elementary students. All sixteen of these schools had climbing structures on the primary grades playground areas. Fourteen of these sites had structures for use by upper elementary students as well.

One (1) of the two schools with special education student populations had a climbing structure.

Discussion

With various forms of climbing apparatus comprising such a significant portion of the equipment on the school playground, it is important that its use is considered very carefully. Information derived from the report to the USCPSC indicates that climbing activities contribute to neuromuscular development and hand-eye coordination. Five-year old children are capable of climbing up and down long ladders and have many of the developmental skills for climbing. However, the ability to descend structures may lag behind in younger children. Some types of equipment may be designed so that it is difficult for children to change directions once climbing is initiated.

As with some other types of playground equipment, as children get used to using it, they may investigate activities not originally intended. The competitive play that becomes more prevalent among children at the end of the primary grades can contribute to this misuse. Activities like jumping from higher and higher points and competing with classmates in "match this" games may lead to injuries. Climbing apparatus, with its multiple uses, may enhance the likelihood of misuse, relative to other types of playground equipment.

Some of the research presented in the USCPSC report indicates that climbing equipment has been associated with high rates of upper limb fractures as well as hospital admissions. The majority of these injuries are because of falls to the surface.

Sliding Boards

Slides were the second most common type of playground equipment found at schools responding to the survey. Slides were present at forty-four (44) of fifty-seven (57) schools. Primary schools were the most likely facilities to have slides. Of the eleven (11) schools in the primary category, ten (10) had at least one slide on site.

Elementary schools without a primary grade component were the least likely to have a slide. Of these schools only five (5) of the eleven (11) surveyed had a slide.

Of the thirty-three (33) schools with primary and upper elementary grades, twenty-nine (29) indicated they had slides. Of these 29 sites, 12 schools indicated that the slide(s) on the playground were undifferentiated as to the specific grade level use. Sixteen (16) schools had sliding boards that were targeted specifically for primary or upper elementary students. All sixteen of these schools had slides for primary playground areas. Thirteen of these sites had slides for use by upper elementary students.

Neither of the two schools with special education student populations had

sliding boards.

Discussion

Survey information indicates that sliding boards are among the most common types of equipment that are found on the elementary playground. The distribution of slides on playgrounds also tends to suggest that slides are more common in schools with a primary grade component. This is consistent with the perception that younger students may enjoy slides more.

The report to the United States Consumer Product Safety Commission (USCPSC) indicates that children under six years of age are more likely to use slides than older children. Children over 3 years of age are developmentally capable of using slides, and with age, begin to use the slide in different manners. Six-year old children tend to start losing interest in slides, and it is suggested that the loss of interest that comes with repetition may foster experimentation with potentially unsafe activities on the slide. These include alternate sliding methods such as head first, on their knees, or running down the incline.

Many of the injuries associated with slides were caused by falls from the slide bed at various points, the ladder while climbing, the starting platform located at the top of the slide, or exiting the slide itself. Also, injuries occurred because of sharp metal edges and corners, and entrapment of clothing, appendages, or the head.

Merry-Go-Rounds

Survey Results

Merry-go-rounds were the least common type of playground equipment found at schools responding to the survey. They were present at only seven (7) of fifty-seven (57) schools. Primary schools proportionally had more merry-go-rounds, though the number was small. Of the eleven schools in the primary category, two (2) had this type of equipment on the playground area.

Of the eleven elementary schools without primary grades only one (1) had a merry-go-round.

Of the thirty-three (33) schools with primary and upper elementary grades, three indicated they had merry-go-rounds. Of these 29 sites, 3 schools indicated that the merry-go-rounds were not differentiated as to the specific grade level use. No school had this type of equipment targeted specifically for primary or upper elementary students in separate play areas.

One principal indicated that the merry-go-round had been removed for safety

reasons. It is unclear if this was because of a specific event or in anticipation of safety problems.

One of the special education schools had a merry-go-round.

Discussion

The USCPSC report notes that many experts have been concerned about merry-go-rounds on playgrounds. As indicated by the one principal's comments on the survey and the very low incidence of merry-go-rounds in all categories of schools, the perception of this equipment as unsafe may be inferred. To the contrary, accident data do not support the view of this equipment as being among the most hazardous types.

Merry-go-rounds are seen as having many benefits. Younger and older children can perform various movements under the rotating conditions which provide a unique and stimulating environment. It has been suggested that the rotating platform provides perceptual challenge, enhancing sensory, cognitive, psycho-social, and motor development.

Hazards occur when the equipment is inappropriately used. Such examples are sitting on the handrails and hanging appendages or leaning over the sides, resulting in falls. Other injuries resulted from pinch points, sharp points, protrusions, and impact with other children. In addition, when children of diverse ages are playing on the equipment, younger children may be unable to get off the equipment as older children take control.

Chinning Bars

Chinning bars were the third most common type of playground equipment found at schools responding to the survey. They were present at thirty-eight (38) of fifty-seven (57) schools. Primary schools were the least likely of the school groups to have separate chinning bars. It is possible that some component of the overall climbing apparatus served a similar function. Of the eleven (11) schools in the primary category, four (4) indicated that chinning bars were present on the playground.

Elementary schools without a primary grade component were more likely to have a chinning bar. Of these schools seven (7) of the eleven (11) surveyed had a chinning bar.

Of the thirty-three (33) schools with primary and upper elementary grades, twenty-seven (27) indicated they had chinning bars. Of these 27 sites, 11 schools

indicated that the chinning bar(s) on the playground were undifferentiated as to the specific grade level use. Sixteen (16) schools had this equipment that was targeted specifically for primary or upper elementary students. Eleven of the sixteen schools had chinning bars for primary playground areas. All sixteen of these sites had chinning bars for use by upper elementary students.

Neither of the two schools with special education student populations had chinning bars.

Discussion

Chinning bars as well as other upper body equipment, have many of the same safety considerations as climbing apparatus. Because of the intended use, the equipment should be high enough so that children will not drag their feet. Activity on chinning bars is more difficult for young children because of the strength required. The low incidence of chinning bars in primary schools supports this observation.

Specific injury data on chinning bars was not available, but it can be assumed some of the similar kinds of activities children perform on other equipment may occur. For example, hooking of the knees over the cross bar and hanging upside down or similar activities, establishes potentially hazardous conditions.

Swings (Regular)

Survey Results

For the purpose of this study, the general category of swings was divided into swings (regular) and tire swings. The common perception of the traditional swing suspended by two ropes or chains which generally move back and forth.

Swings (regular - single axis) were the fourth most common type of playground equipment. Swings were present at thirty-six (36) of fifty-seven (57) schools. Primary schools were the most likely to have swings. Of the eleven (11) schools in the primary category, eight (8) had swings.

Elementary schools without a primary grades were the least likely to have a swings. Of these schools only three (3) of the eleven (11) surveyed had a regular swings.

Of the thirty-three (33) schools with primary and upper elementary grades, twenty-three (23) indicated they had regular swings. Of these 23 sites, 9 schools indicated that the swings on the playground were undifferentiated as to the specific

grade level use. Fourteen (14) schools had swings that were intended specifically for primary or upper elementary students. All fourteen of these schools had regular swings for primary playground areas. Eleven (11) of these sites had separate swings for use by upper elementary students.

Both of the schools with special education student populations had regular swings.

Discussion

The USCPSC report notes that research on children's preference in playground equipment rates swings as the most popular. Swings may serve an important function in the development of a sense of balance and movement. Muscle development as well as stimulation to the inner ear during the pendulum motion of the swing adds to perceptual and motor development and a sense of one's body in space.

The motor skills necessary for swinging are present in children in kindergarten and younger. Even with young children, though, there is very little interaction among swing users. Among older children this becomes even more so. As swing use becomes less exciting for older children, other uses emerge, and some of these activities can be potentially dangerous. Jumping from swings and standing or kneeling on swings can contribute to falls.

For children five and older, more common injuries were associated with the upper limbs. Falls were the predominant cause of injury. Loss of grip, being pushed out of the swings as well as other activities contribute to these falls. Impact with moving swings, pinch points, sharp edges, finger entrapment, and equipment failure were also causes of injuries associated with swings. There have been a number of fatalities associated with entanglement in the swing chains or ropes.

Tire Swings

Survey Results

Tire swings were present at ten (10) of fifty-seven (57) schools surveyed. Primary schools were the most likely facilities to have tire swings. Of the eleven (11) schools in the primary category four (4), had at least one.

Elementary schools without primary grades have about the same number of sites with tire swings. Of these schools three (3) of the eleven (11) surveyed had this equipment.

Of the thirty-three (33) schools with primary and upper elementary grades, ten (10) indicated they had tire swings. Of these 10 sites, all schools indicated that the tire swing(s) on the playground were intended for either primary students or upper elementary students. There were no undifferentiated-use tire swings. Two (2) schools had tire swings that were targeted specifically for primary playground areas. Only one (1) sites had tire swings for use by upper elementary students.

Neither of the two schools with special education student populations had tire swings.

Discussion

Tire swings have become increasing popular on playgrounds because of their 360 degrees of rotation and the unique play experience this provides. An additional advantage of tire swings in comparison to regular swings is that more than one child can be seated. Research described in the USCPSC report indicates that there may be fewer serious injuries associated with this type of swing.

The type of tire used in the swing is very important. Used automobile tires can be quite heavy and could be a substantial impact danger. Radial tires should be avoided. Some manufacturers offer lightweight simulated tires made from plastic or rubber.

Ground clearance is generally low, so falling is less of a danger. The supporting structure needs to have appropriate clearances on all sides to prevent impact injury.

Horizontal Ladders

Overhead horizontal ladders were as common as swings in terms of the numbers of elementary schools having them on site. This makes it the fourth most common category of playground equipment. Generally, horizontal ladders are grouped as climbing structures, but the skills and strength involved with using this equipment appropriately warrants them as a separate category. Horizontal ladders were present at thirty-six (36) of fifty-seven (57) schools. Of the eleven (11) schools in the primary category, six (6) had horizontal ladders on the playground site.

Of the elementary schools without primary grades, four (4) of the eleven (11) surveyed had at least one horizontal ladder.

Of the thirty-three (33) schools with primary and upper elementary grades, twenty-six (26) indicated they had horizontal ladders. Of these 26 sites, 12 schools indicated that this equipment was undifferentiated as to the specific grade level use.

Fourteen (14) schools had horizontal ladders that were intended specifically for primary or upper elementary students. Nine (9) of these schools had horizontal ladders for primary playground areas. Eleven (11) of these fourteen sites had horizontal ladders for use by upper elementary students.

Neither of the two schools with special education student populations had horizontal ladders.

Discussion

Many of the safety precautions associated with climbing equipment apply to horizontal ladders. The USCPSC report suggests that many injuries on such equipment result from falls and occur because of hazardous use. Examples of this activity include horseplay such as being pushed or falling while standing on top of the ladder. Also skipping rungs while progressing across the ladder or hanging upside down provided potentially dangerous situations.

See-Saws

Survey Results

See-saws were present at twenty-two (22) of fifty-seven (57) schools surveyed. Primary schools were the most likely facilities to have see-saws. Of the eleven (11) schools in the primary category, more than half, six (6) schools, had at least one.

Elementary schools without primary grades had proportionally fewer sites with see-saws. Of these schools only three (3) of the eleven (11) surveyed had this equipment.

Of the thirty-three (33) schools with primary and upper elementary grades, twenty-two (22) indicated they had see-saws. Of these 22 sites, six (6) schools indicated that the see-saws(s) on the playground were undifferentiated as to the specific grade level use. Eight (8) schools had see-saws that were targeted specifically for primary or upper elementary students. Seven (7) of these schools had see-saws for primary playground areas. Only three (3) of these sites had see-saws for use by upper elementary students.

Neither of the two schools with special education student populations had see-saws.

Discussion

The USCPSC report indicates that see-saws are not as readily available as they

once were. There appears to be an increasing view that this equipment has a limited function for dramatic and constructive play.

Most of the injuries associated with see-saws resulted from falls. Striking the see-saw while on it accounted for a smaller number of injuries. Children on the high end of the see-saw are susceptible to falls, sometimes due the partner's rapid dismount, leaving the board to plunge quickly to the surface. Splinters from worn wooden equipment have also caused some problems.

For the youngest children, the see-saw is a complex piece of equipment requiring cooperation and integration of actions. This may be somewhat difficult for them. Older children may not find the activity of the see-saw stimulating, and they may seek alternate and potentially unsafe uses.

Firemen's Pole

Survey Results

Firemen's poles (sliding poles) were present at fourteen (14) of fifty-seven (57) schools surveyed. Firemen's poles were found at all different types of school sites in relatively small numbers, and no clear trend was observed. Of the eleven (11) schools in the primary category, only two (2) schools, had at least one.

Elementary schools without primary grades had even fewer sites with sliding poles. Of these schools only one (1) of the eleven (11) surveyed had this equipment.

Of the thirty-three (33) schools with primary and upper elementary grades, eleven (11) indicated they had this equipment. Of these eleven sites, three (3) schools indicated that the poles(s) on the playground were undifferentiated as to the specific grade level use. Eight (8) schools had firemen's poles that were targeted specifically for primary or upper elementary students. Seven (7) of these schools had sliding poles for primary playground areas. Five (5) of these sites had sliding poles for use by upper elementary students.

Neither of the two schools with special education student populations had this type of equipment.

Discussion

Injury data for firemen's poles is unavailable; however, as this equipment is frequently part of interconnected climbing systems many of the same types of information have some application. Some of the major considerations for the sliding poles is that the pole be separated from the access platform so that the child

using it has adequate clearance as he/she descends. The USCPSC report suggest that this equipment not be made available to preschool children as the upper body strength and coordination required may be lacking. In addition, the child has no options but to finish the descent once on the pole.

Trapezes

Survey Results

Trapezes were one of the least common types of playground equipment found at schools responding to the survey. Trapezes were present at only nine (9) of fifty-seven (57) schools. There was no clear pattern to indicate what organization of school was more likely to have a trapeze. Of the eleven (11) schools in the primary category, only (1) indicated there was at least one on site. Elementary schools without a primary grade component were similarly not likely to have a trapeze. Of these schools only one (1) of the eleven (11) surveyed had a trapeze.

Of the thirty-three (33) schools with primary and upper elementary grades, seven (7) indicated they had a trapeze. Of these 7 sites, four (4) schools indicated that the trapeze(s) on the playground were undifferentiated as to the specific grade level use. Three (3) schools had trapezes that were intended specifically for either primary or upper elementary students. Only one of these schools had a trapeze for primary playground areas. Two of these sites had trapezes for use by upper elementary students.

Neither of the two schools with special education student populations had trapezes.

Discussion

Safety information on trapezes was unavailable. As this equipment shares many of the characteristics of climbing apparatus, it is assumed there are many similar considerations with its operation. As upper body strength is necessary for using this equipment, it would most likely be less appropriate for the youngest students in the public schools. As with all of the equipment, there are opportunities for its misuse which could create safety problems.

Other Equipment

Survey Results

A variety of additional playground equipment was included on the survey by principals. There were relatively few additional items reported. It is possible some

similar items were included in the integrated playground equipment schools have, but were not described by the individuals completing the surveys. The items that were included in the other category were balance beams, parallel bars, animals on springs (rocking horses), swinging bridges, forts and houses, chutes (a variety of sliding boards), fitness centers, and exercise stations. From the survey responses these types of equipment show no clear use trends with student age ranges.

School Organization							
Equipment	Primary	Upper Elementary	Pre-Kindergarten - Upper Elementary			Special Schools	Total
	11 Schools	11 Schools	33 Schools			2	57
			Combined Play areas	Separated* Play Areas	Total		
Slides	10	5	12	16 / 13	29		44
Merry-go-round	2	1	3		3	1	7
See-Saw	6	2	6	7 / 3	14		22
Swing	8	3	9	14 / 11	23	2	36
Tire Swing	4	3		2 / 1	3		10
Climbing Apparatus	11	7	13	16 / 14	30	1	48
Horizontal Ladder	6	4	12	9 / 11	26		36
Chinning Bars	4	7	11	8 / 16	27		14
Fireman's Pole	2	1	3	7 / 5	11		14
Trapeze	1	1	4	1 / 2	7		9

* The number of pieces of equipment found on a separate primary playground/the number of pieces of equipment on a separate upper elementary playground at the same school

Playground Equipment for Students with Disabilities

Survey results from elementary school principals, indicated that equipment specifically designed for students with disabilities was very limited. Out of the fifty-three (53) schools responding to this item, only four (4) reported the presence of such equipment on their school playgrounds. The two additional schools that house primarily special population students both had limited equipment and only one school reported that the playground equipment was specifically adapted for its students.

**Availability of Playground Equipment
for Students with Disabilities**

	Primary Schools	Upper Elementary Schools	Combined Schools	Total
Yes	2	1	1	4
No	9	10	30	49

Playground Surfaces

Survey Results

On the survey, principals responded to the type of surface that was beneath the playground equipment. They were requested to include all types present on the school playground(s) since segregated pieces of equipment might be underlain by different surfaces. Tabulation of the responses clearly shows that grass and dirt (essentially no special resilient surface) were predominant. The following is a chart of surfaces and the frequency of responses describing the results of the questionnaire item.

Grass	32
Dirt	29
Sand	17
Wood Chips	12
Gravel	4
Concrete	2
Shredded Rubber	1
Other	1
Synthetic Mats	0

Discussion

The USCPSC report indicates that falls represent the most common cause of injury on the playground. Falls from equipment were also the most common cause of playground injury reported by school divisions in Virginia. Furthermore, USCPSC data indicates that 52% of the injuries resulted from a fall onto grass--the most prevalent surface reported by Virginia principals. 66% of injuries in the USCPSC study resulted from a fall of less than six (6) feet. The USCPSC also reports that the prevalence of fall-related fatalities, especially those resulting from a head injury, demonstrates the need for resilient playground surfaces.

Protective surfaces showed a lower rate of severe injuries both for the head and upper limbs than paved surfaces. Data on natural surfaces (grass and dirt) as compared to protective surfaces are inconclusive because of limited systematic controls in the studies. However, studies and information exist that detail the advantages and disadvantages of various protective surface materials.

It is vital that those with responsibility for playground safety at the school building level ensure that appropriate surfaces are in place under equipment and that these surfaces receive regular maintenance. Protective surfaces, such as sand wood chips, and shredded rubber, can be rendered less effective by the normal play activity spreading it about.

A variety all of the types of equipment can be appropriate for the various student age groups in the elementary schools. The major consideration must be if the specific piece is appropriate as installed. For example, horizontal ladders for primary students need to reflect the physical dimensions of this age group. The unit should be of an appropriate height, with a different span between rungs than the same type of equipment a 5th grade student would use.

All pieces and types of equipment should be evaluated very carefully by individual principals to determine if the equipment is meeting the needs of the students served at that particular school. Also, strong consideration should be given to developing distinct areas for primary and upper elementary students that are housed in a multi-grade site.

One of the most important considerations is that of supervision. Rarely are teachers given instruction on safe play and their role in the supervision of play on equipment. Likewise, parents need to be educated on how to supervise their children on playgrounds. All students will find new and creative uses for the equipment that were not originally intended. Inappropriate use and horseplay appear to contribute significantly to unsafe activities. Close supervision by adults can counteract this.

Chapter II

Injuries Sustained on Public School Playgrounds in the Commonwealth

A Division-wide Playground Safety Information Request was sent to each LEA on June 5, 1991 through Superintendent's Memorandum No. 53 (Administrative). (See Appendix E). Seventy-five (75) LEAs completed and returned the survey. Superintendents or their designees were asked to submit information regarding the number of playground accidents requiring professional medical attention; the number of accidents by type and cause for the most recent year for which complete data exists; and other information regarding the need for playground standards, local reporting procedures; and the presence of before/after school care on school property.

Number of Playground Accidents Requiring Professional Medical Attention

Sixty-five (65) LEAs reported a total of 5,700 injuries during the 1990-91 school year. Based on LEA reports, of the 348,976 students enrolled in schools which have playgrounds, 1.75% of the children in these schools sustained an injury requiring professional medical attention.

Data for the 1989-90 school year was received from 56 LEAs. School divisions indicated that 3,697 accidents occurred. Thus, 1.26% of the students in schools with playgrounds suffered an accident requiring professional medical attention during the 1989-90 school year.

Number of Accidents Requiring Medical Attention*				
	1990-91 School Year	1989-90 School Year	1988-89 School Year	1987-88 School Year
No. of Divisions Responding	65	56	47	35
No. of Accidents	5,700	3,697	1,526	951

Note: Severity of the injuries is unknown.

Approximate Number of Accidents by Type

School divisions were asked to indicate the approximate number of accidents in accordance with the following categories: abrasions, cuts, or puncture wounds; eye injuries; sprains/strains; broken bones; head injuries; and other. LEAs reported 12,734 injuries during the last year for which they had complete information. (This figure is significantly greater than any of the figures for the number of playground accidents occurring in any one school year. It is hypothesized that LEAs may maintain categorical information regarding accidents by type [i.e. broken bones, eye injuries, etc.] without cross-referencing the location where the injury [i.e. playground, classroom, etc.] occurred. It is also possible that one accident may result in multiple injuries [i.e. a fall from a climber may result in a broken bone and an abrasion] to the student involved, and/or that these figures include injuries such as minor cuts and scrapes which did not require professional medical attention.)

On the total number of accidents reported, 52.86% were abrasions, cuts, or puncture wounds. The next largest categories of injuries involved sprains/strains at 13.55%, head injuries at 12.54%, and other injuries at 12.43%. Broken bones constituted 5.19% of the injuries, while eye injuries accounted for 3.43% of the injuries.

Playground Accidents by Type*		
Injury Type	No. of Reported Accidents	% of Total Accidents
Abrasions, Cuts or Puncture Wounds	6,732	52.86
Eye Injuries	438	3.43
Sprains/Strains	1,726	13.55
Broken Bones	661	5.19
Head Injuries	1,594	12.54
Other	1,583	2.43
TOTAL	12,734	100%

***NOTE: Severity of the injuries is unknown**

Approximate Number of Accidents by Cause

LEAs reported 5,599 accidents by cause for the last year for which they had complete information. Falls from equipment accounted for 30.09% of the accidents. Bumping into stationary equipment was the cause for 23.43% of the injuries, and impact with moving equipment was the cause for 8.47% of the injuries. Contact with protrusions, sharp edges, or pinchpoints was the causal factor in 3.20% of the accidents, while 3.05% of the injuries resulted from playground debris. Equipment tipover and equipment failure were very minor factors accounting for only 0.23% and 0.16% of the accidents respectively. Miscellaneous other factors were responsible for 29.93% of the accidents.

Playground Accidents by Cause		
Injury Type	No. of Reported Accidents	% of Total Accidents
Falls from Equipment	1,685	30.09
Impact with Moving Equipment	474	8.47
Bumping into Stationary Equipment	1,312	23.43
Contact with Protrusions, Sharp Edges or Pinchpoints	179	3.20
Entanglement/Entrapment	80	1.43
Equipment Tipover	13	0.23
Equipment Failure	9	0.16
Playground Debris	171	3.05
Other	1,676	29.93
TOTAL	5,599	99.99

Chapter III

Playground Safety Initiatives

Initiatives in Other States

Two procedures were used in order to ascertain playground safety initiatives in other states. A letter and survey was sent to state physical education directors in each of the fifty states. This letter and survey asked if the state has statewide guidelines concerning playground safety (See Appendix G). Of the fifty states surveyed, thirty-three (33) responded. This was a 66% return rate. Out of the thirty-three states returning the survey, only two states, Kansas and Louisiana, indicated that state guidelines have been established (See Appendix K). Four other states, Nevada, Iowa, New Mexico and Wisconsin, reported that they follow guidelines established by either the U. S. Consumer Product Safety Commission, the American Alliance of Health, Physical Education, Recreation and Dance, or Wausau Insurance Company.

A second source of information concerning playground safety initiatives in other states was the publication entitled *Analysis of the State Regulations for Elementary Schools*. (See Appendix L). This document reports the results of a study conducted by Frances Wallach, Ed. D., project director for Total Recreation Managements Services, Inc., and Susan Edelstein M.A., chief researcher at New York University. According to this study, nine states have guidelines for playground equipment and seven states have guidelines for playground surfaces. However, after reviewing the guidelines submitted by these states for this report, it was found that there is a great deal of variability concerning the interpretation of the term "regulations." In several cases, what was listed as a regulation appeared to be recommended guidelines for playground equipment and surface review.

Included below are examples of several states' guidelines, standards or regulations which demonstrate a variety of responses to playground safety issues.

California

Play Equipment:

Senate Bill 946 (8/16/84) restricts wood preservatives used for new wood playground or recreational equipment and requires treatment if certain wood preservatives were used to treat existing wooden playground or recreational equipment.

Delaware

State Policy:

Delaware policy is that each school district adopts a policy statement that addresses installation, maintenance, operation, periodic self-inspection, and use of playgrounds and playground equipment with emphasis on safe use by students and the public. Each principal is responsible for forming an ad-hoc advisory committee to assist in implementing and monitoring established district policy concerning playground safety.

Colorado

Play Equipment:

There should not present a mechanical hazard to children. Should be structurally stable and constructed of durable, weather resistant materials; there should be no projecting screws or bolts, sharp cutting edges, pinch points or splinters; should be free from rust and chipping paint; anchors for all equipment should be stable and buried below ground level; should be adequately fenced from nearby hazards.

Surfacing:

Should be 8-12 inches of shock-absorbing material (such as loose pea gravel or wood chips) underneath all equipment. Surface should be free of projections, cracks, depressions that can cause tripping injuries; should be under all equipment and should extend 3 feet beyond it.

Kansas

Play Equipment:

Follows all equipment guidelines established by the USCPSC for swings, merry-go-rounds, teeter-totter, slides, and climbers, all cluster equipment.

Surfacing:

Safe surfaces are mandatory under all manufactured equipment. Play surfaces include: turf, unmown rough areas suitable for used by crawling infants, and non-accessible erosion control areas. Surfacing should meet the under 200 g USCPSC impact attenuation standard. Fall absorbing surfaces must be installed in all equipment settings. Careful maintenance is required of all surfaces. Hard-surface pathways are needed for accessibility.

Maryland

Play Equipment :

Must be constructed of materials which have proved durable in a playground or outdoor setting. Materials subject to corrosion or deterioration should be plated, galvanized, painted, preserved, or otherwise treated to resist these effects. Equipment should be installed according to manufacturer's instructions. Legs of equipment should be set in concrete for stability. All types of anchoring devices should be placed below ground level to avoid a tripping hazard. Install swinging equipment a safe distance away from fences, building walls, walkways, and other play areas.

Surfacing:

This state adheres to USCPSC guidelines that installation of equipment should not occur over hard surfaces such as concrete, blacktop or cinders.

Massachusetts

Play Area :

Outdoor play area should be accessible to children with special needs, with a minimum of 75 square feet per child; if in a hazardous area, the play area is fenced by a barrier at least four-feet high; the play area is checked daily for glass, broken equipment, or other hazards.

Surfacing:

Sufficient quantities of impact absorbent materials are used under climber, slides, swings, or see-saws. Climbing equipment, swings, and very large or top-heavy pieces of indoor furniture are securely anchored.

New York

State Policy

The State Education Department requires that all new playground installations be in conformance with the USCPSC guidelines.

Tennessee

Play Equipment:

There must be outdoor play equipment for children who are in care more than 3 daylight hours; all outdoor play equipment must be sufficient in amount and variety so that children can take part in many kinds of play each day; all outdoor play equipment must be placed to avoid accidents; supports for climbers, swings, and other heavy equipment that could cause injury if toppled must be securely anchored to the ground, even if the equipment is designed to be portable; must be well made and safe. No sharp edges, splinters, or nails sticking out. Must be age-appropriate equipment.

Surfacing:

A resilient surface is required under climbers (including slides) and swings. A surface such as one of those below should be used under any piece of equipment which puts a school age child 2-1/2 feet off the ground. Any kind of climbing apparatus, the ladder or steps on a slide as well as the end of the slide, a seesaw, swings, and a merry-go-round, all require resiliency under and around them where a child might fall. The resilient surface should extend at least 2 feet beyond climbers and at least 4 feet from the end of the slide. Acceptable "soft" surfaces are grass, coarse sand, pea gravel (medium-sized is best), wood chips, sawdust, straw, indoor/outdoor carpet, artificial turf, rubber matting. Other surfaces are not precluded if proper resilience is provided.

Supervision:

Staff/Pupil Ratio on the Playground -- 1:25

West Virginia

Play Area:

All schools with a kindergarten program contain a segregated blacktopped area and a large grassy area with climbing equipment and swings. The playground may be segregated by either time or space allocation.

Initiatives of Professional Organizations

Several organizations which might have an interest in playground safety initiatives were contacted for input into this study. Letters were sent to the American Academy of Pediatrics (AAP), Virginia Association for Elementary School Principals (VAESP) and Virginia Congress of Parents and Teachers requesting information about playground safety recommendations or standards adopted or desired. (See Appendix Q).

Michelle Zajac, Project Manager, Division of Child and Adolescent Health, American Academy of Pediatrics responded to our inquiry on playground safety initiatives. Her response included a brochure on safety tips for home playground equipment and a section from the AAP child care book, Caring for Your Baby and Young Child - Birth to Age 5. The recommendations outlined in this material provided broad guidelines for selecting playground equipment and sites. The AAP did not indicate they supported any specific playground safety initiatives.

Don Lacy, the Executive Director of the Virginia Association of Elementary School Principals, responded to the inquiry. He indicated there is a concern about the safety of school playground equipment. Also, he voiced a concern about playground equipment purchased hastily after fund raising efforts at individual schools sites.

The National Association for the Education of Young Children (NAEYC) outlines the following criteria for outdoor equipment and playground safety in its document, Accreditation Criteria and Procedures of the National Academy of Early Childhood Programs:

- The indoor and outdoor environments are safe, clean attractive, and spacious. There . . . is a minimum of 75 square feet of play space outdoors per child;
- Private areas are available indoors and outdoors for children to have solitude;
- The outdoor area includes a variety of surfaces such as soil, sand, grass, hills, flat sections, and hard areas for wheel toys. The outdoor area includes shade; open space; digging space; and a variety of equipment for riding, climbing, balancing, and individual play. The outdoor area is protected from access to streets and other dangers;
- The building and all equipment are maintained in a safe, clean condition and in good repair (for example, there are no sharp edges,

splinters protruding or rusty nails, or missing parts);

- Cushioning materials such as mats, wood chips, or sand are used under climbers, slides, or swings. Climbing equipment, swings, and large pieces of furniture are securely anchored;
- . . . Individual medical problems and accidents are recorded and reported to staff and parents;
- At least one staff member, who has certification in emergency first aid treatment and cardiopulmonary resuscitation (CPR) from a licensed health professional, is always in the center; and
- Adequate first aid supplies are readily available. A plan exists for dealing with medical emergencies.

The National Safety Council has published extensive guidelines in its publication Safety First Checklist - The Site Inspection System for Playground Equipment. (See Appendix R). The exhaustive checklist includes information on site surveys, surfacing, and a large variety of playground equipment.

Chapter IV

Primary Manufacturers of Playground Equipment and Federal Standards

Most major manufacturers of playground equipment and playground resilient surfaces belong to the National Parks and Recreation Association. This organization was contacted in order to establish a list of primary manufacturers; however, it maintains no such listing. Thus, the following list was prepared by consulting dealers of playground equipment and cross-referencing with other sources.

Playground Equipment Manufacturers:

Landscape Structures, Inc.
601 7th Street South
Delano, MN 55328
(800) 328-0035

Children's Playground Inc.
55 Whitney Street
Holliston, MA 01746
(508) 429-3870

Gametime, Inc.
P.O. Box 121
Fort Payne, AL 35967
(205) 845-5610

PCA Industries, Inc.
5042 Natural Bridge
St. Louis, MO 63120
(800) 727-8180

Miracle Recreational Equipment
P.O. Box 420
Monett, MO 65708
(417) 235-6917

Iron Mountain Forge
1 Iron Mountain Drive
Farmington, MO 63640
(314) 756-4591

Big Toys
7717 New Maricet Street
Olympia, WA 98501
(800) 426-9788

Play Design
P.O. Box 427
New Berlin, PA 17855
(800) 327-7571

Kompan
80 King Spring Road
Windsor Locks, CT 06096
(203) 623-4139

Artificial Resilient Surfaces Manufacturers:

Tennek
311 Albans Port
Malvern, PA 19355
(215) 296-4514

Tire Turf Systems, Inc,
P.O. Box 186
Harlan, IN 46743
(219) 657-5129

The Mat Factory
1378 E. Edinger
Santa Ana, CA 92705
(714) 547-7623

Standards and guidelines on playground safety have been established by federal and national organizations. These organizations, the U.S. Consumer Product Safety Commission (USCPSC) and the American Society for Testing and Materials (ASTM), are also in the process of preparing additional standards.

The USCPSC publication, "A Handbook for Public Playground Safety", is a set of guidelines for playgrounds. Volume I of this handbook is entitled "General Guidelines for New and Existing Playgrounds", and Volume II of the same handbook is "Technical Guidelines for Equipment and Surfacing." (See Appendix M). The USCPSC also commissioned the COMSIS corporation to conduct a study of playground safety and make recommendations. The final report, known as the COMSIS Corporation Report, is to be adopted as a national standard in the fall of 1991 by the USCPSC (See Appendix N).

Existing ASTM standards cover various aspects of the playground, ranging from the equipment itself to surfacing materials. With respect to resilient services, for example, ASTM F 1292, entitled "Specifications for Impact Attenuation of Surface Systems Under and Around Playground Equipment", sets standards for the types of surfacing materials to be used in and around playground. ASTM F 355-1986 sets tests for determining shock absorbing properties of playing surface systems and materials, and ASTM's F 1015, "Tests for Relative Abrasiveness of Synthetic Turf Playing Surfaces", refers to standards of abrasiveness of synthetic turfs.

Although ASTM has developed a full set of standards and specifications (ASTM F 1148-91) related to residential equipment, it has not yet developed a final set of standards and specifications for public playground equipment. ASTM Subcommittee F 15.29 is working to develop standards for materials, entrapment,

protrusion, loading of equipments (decks, swings and slides), spacing of support poles, clear areas around equipment and distances between walls and equipment.

Another subcommittee, ASTM F 8.52, is developing standards on "Shock Absorbing and Impact Attenuation of Surfaces." It will recommend the thickness of surfacing materials necessary to cushion impact forces of 200 times the force of gravity, and to yield an H.I.C. (Head Injury Criteria) of less than 1000. This subcommittee is also investigating standards for making playground surfaces accessible to individuals with physical disabilities.

Other sources of information used by manufacturers in setting standards for their equipment are independent organizations such as the University of Michigan Transportation and Research Institute. Their "Anthropometric Data" is used for children's head sizes, reach, grabbing height and other information.

The National Parks and Recreation Association is a friendly business association and does not maintain standards. However, most of its members are also members of the ASTM, and follow the latter's standards as well as USCPSC standards and guidelines for construction quality and safety.

Chapter V

School Division Recommendations Concerning Statewide Standards

To determine local school division opinion concerning the need for playground equipment standards, elementary school principals and school division superintendents or their designees were surveyed (see Appendices E and F) for responses to the following questions:

- Have you planned a review of your playground equipment or taken any other action because of the new standards which have been developed and adopted by the U. S. Consumer Product Safety Commission?
- Is there a need for such uniform, research-based standards to ensure: the safety of school playgrounds and equipment; age appropriateness of such equipment; and/or the repair and replacement of broken and obsolete equipment?
- Do you have a requirement for such accidents to be reported to: the division superintendent; local health officials; and/or state health officials?

In response to the question concerning the review of playground equipment, 33% of the responding elementary school principals and 59% of the superintendents/designees reported that they have planned a review in accordance with the new standards developed by the U. S. Consumer Product Safety Commission. It appears, therefore, that at both the school building and central office level there is an interest in the safety of playground equipment to the extent that playgrounds are being reviewed in terms of the U. S. Consumer Product Safety Commission standards. There were several anecdotal comments on the principals' surveys indicating that playground equipment is routinely inspected though they weren't using the U. S. Consumer Product Safety Commission standards.

Responses to questions relative to the need for standards indicated that the responding elementary school principals and superintendents/designees do feel there is a need for uniform research-based standards. When asked whether there is a need for standards to ensure the safety of school playgrounds and equipment, 81% of the elementary school principals and 81% of the superintendents/designees felt there is such a need. When asked about standards for the age appropriateness of such equipment, 77% of the responding elementary school principals and 81% of the superintendents/designees indicated a need exists. A tabulation of the responses to the question about whether standards are needed for the repair and replacement

of broken and obsolete equipment revealed that 79% of the elementary school principals and 81% of the superintendents/designees specified a need for standards.

Chapter VI

Implications of Day Care Program and Before and After School Child Care Program Licensing Requirements

House Bill 1035, which was passed by the 1990 General Assembly, calls for a revision of the minimum standards for licensed child care centers, before and after school child care programs, and child day care camps serving school age children. The proposed minimum licensing requirements address playground safety concerns by establishing standards for playground equipment and surfaces. (See Appendix O). According to Liz Campbell, Program Development Supervisor, with the Department of Social Services, Division of Licensing Programs, House Bill 1035 may impact those playgrounds of elementary schools which house before and after school child care programs.

School divisions were asked if they or a contractee used any of their school sites to operate child-care or extended-day programs before or after school. LEAs reported a total of 219 school serving 13,187 children in extended day child care programs. Twenty-four (24) or 32% of the LEA's responding to the survey had at least one child care site.

There is evidence of an increased emphasis on extended day child care programs as specified through state initiatives such as child care and development block grants. (See Appendix P) Therefore, it is probable that there will be increase in the number of before and after school child care programs on school sites.

Concluding Chapter

Relevant Trends

This study of the safety of school playgrounds has revealed several trends which are noteworthy for the development of recommendations. These trends include:

- A significant number of school divisions operate before and after school day care programs on school sites. Moreover, with increased emphasis on such programs as specified through state initiatives such as child care and development block grants, it is probable that there will be an increase in the number of before and after school child care programs on school sites. Schools that house such programs will need to be in compliance with the minimum standards for licensed child care centers and before school and after school child care programs as promulgated by the Department of Social Services.
- 81% of all the elementary school principals and superintendents/designees responding to the surveys indicated there is a need for uniform standards to ensure the safety of playgrounds and equipment.
- 77% of all responding elementary school principals and 81% of the superintendents/designees felt there is a need for standards regarding the age-appropriateness of playground equipment.
- 79% of the sample elementary school principals and 72% of the superintendents who responded indicated a need for standards to ensure the repair and replacement of broken and obsolete equipment.
- Approximately 5,700 students in seventy-five (75) school divisions were injured in varying degrees of severity as a result of injuries on playgrounds during the 1990-91 school year. The apparent rate of head injuries and other potentially severe injuries occurring on school playgrounds indicates a need for further study.
- The executive director for the Virginia Association of Elementary School Principals indicated there is a concern about the safety of school playground equipment, especially in regards to equipment which may be purchased hastily after fund raising efforts.
- While significant progress has been made in accomodating children

with disabilities in school buildings, school playgrounds remain largely unchanged. Inaccessible playgrounds force children with special needs to be spectators rather than participants in outdoor activities, thereby limiting their development of motor and social skills.

- There are indications that several states are considering the adoption of the playground equipment standards developed by the U. S. Consumer Product Safety Commission.

Study Team's Recommendations

Based on the noted trends and information provided, the playground safety study team proposes the following recommendations:

- Playground safety information packets should be produced and disseminated to all elementary schools. These packets should include the U. S. Consumer Product Safety Commission's video and standards.
- State guidelines, standards or regulations should be established. These guidelines should be based on the playground safety standards under development by the USCPSC. These standards are scheduled to be released during the fall of 1991. The standards also should correlate with the Department of Social Services standards established for licensing day care and before and after school program facilities.
- Any standards, guidelines or regulations should include recommendations for establishing separate play areas, with appropriate playground equipment, for the various age groups that are housed at each school.
- Standard reporting forms and procedures for collecting information concerning playground injuries should be developed. This would provide accurate data regarding the extent of injuries on public school playgrounds.
- If state guidelines, standards, or regulations are established, financial assistance should be made available to school divisions in order to aide them in achieving compliance with the regulations, thereby reducing the risk of serious injury to Virginia school children.

Appendixes

Appendix A	House Joint Resolution No. 473
Appendix B	Request for Proposal (RFP) 91-29
Appendix C	Early Childhood Proposal for RFP 91-29
Appendix D	Letters Concerning Consultants' Assistance
Appendix E	Superintendent's Memo No. 53.- Division Surveys
Appendix F	Elementary School Survey
Appendix G	Survey to Physical Education Directors at State Education Agencies throughout the U. S.
Appendix H	ERIC Search of Literature Concerning Playground Safety
<p>Note: Appendix H is lengthy and has not been included in this report in order to save printing costs. This appendix may be obtained from Valerie Barrett's office, Early Childhood Division - 20th floor, Commonwealth of Virginia, Department of Education, P. O. Box 6-Q, Richmond, Virginia 23216.</p>	
Appendix I	Virginia Physical Education City and County Supervisors' Committee on Playground Safety
Appendix J	Letter Establishing Meeting with Liz Campbell, Supervisor of Programs, Department of Social Services, Division of Licensing Programs

Appendix R

Safety First Checklist - The Site Inspection System for Play Equipment, Produced by the National Safety Council

Note: Appendix R is lengthy and has not been included in this report in order to save printing costs. This appendix may be obtained from Valerie Barrett's office, Early Childhood Division - 20th floor, Commonwealth of Virginia, Department of Education, P. O. Box 6-Q, Richmond, Virginia 23216.

Appendix A

House Joint Resolution No. 473

1991 SESSION

LD9196434

1 **HOUSE JOINT RESOLUTION NO. 473**
2 **AMENDMENT IN THE NATURE OF A SUBSTITUTE**
3 (Proposed by the House Committee on Rules
4 on February 2, 1991)

5 (Patron Prior to Substitute—Delegate Christian)

6 *Requesting the Department of Education to study the safety of school playground*
7 *equipment.*

8 WHEREAS, physical activity is an integral part of a child's day and essential to his
9 growth and development; and

10 WHEREAS, § 22.1-207 of the Code of Virginia requires that "physical education be
11 emphasized throughout the public school curriculum by lessons, drills and physical
12 exercises," and children in the elementary grades often use playground equipment as a
13 part of such instruction and during recess periods; and

14 WHEREAS, although much school playground equipment is donated, lessening the costs
15 for such items to local school boards, large sums are spent to purchase playground
16 equipment, particularly for newly constructed schools; and

17 WHEREAS, the control of school playground equipment is the responsibility of the local
18 school board, and there are no state regulations or guidelines that establish standards for
19 school playgrounds; and

20 WHEREAS, much school playground equipment may be obsolete, worn out, in disrepair
21 or inappropriate for young children, and an inventory of the condition of such equipment
22 has never been conducted; and

23 WHEREAS, although numerous children are hurt each year in playground accidents,
24 there are no standards for playground equipment or guidelines for the repair and
25 replacement of old and broken equipment; and

26 WHEREAS, because it is important to ensure that the equipment on which young
27 children play is safe and age appropriate, serious consideration should be given to
28 establishing standards to ensure the safety of playground equipment and regulations and
29 guidelines to require the repair of broken equipment and the timely replacement of
30 obsolete and worn equipment; now, therefore, be it

31 RESOLVED by the House of Delegates, the Senate concurring, That the Department of
32 Education be requested to study the safety of school playground equipment.

33 The Department shall (i) undertake a review of the types of playground equipment in
34 use by the public schools and the age range of the children for whom such equipment was
35 purchased; (ii) determine the number of children hurt in playground accidents each year,
36 the types of injury, the causes of such accidents, and whether such incidents are required
37 to be reported to the division superintendent and local or state health officials; (iii) review
38 the initiatives in other states to establish safety standards for school playgrounds and
39 equipment, and the safety standards desired by professional medical and educational
40 associations and interested consumer groups; (iv) identify the primary manufacturers of
41 playground equipment and whether there are any federal regulations and standards,
42 manufacturer's internal quality control standards, or guidelines for the construction, quality,
43 and safety of playground equipment established by a recognized association of the
44 manufacturers of playground equipment to which such manufacturers must adhere; and (v)
45 determine the need for statewide standards to ensure the safety of school playgrounds and
46 equipment, the age appropriateness of such equipment, and regulations or guidelines for the
47 repair and replacement of broken and obsolete equipment.

48 The Department shall complete its work in time to submit its findings and
49 recommendations to the Governor and the 1991 General Assembly as provided in the
50 procedures of the Division of Legislative Automated Systems for processing legislative
51 documents.

52

53

54

Appendix B

Request for Proposal (RFP) 91-29

RFP- Request for Proposal # 91-29

Virginia Department of Education

TITLE:

Safety of School Playground Equipment

BACKGROUND:

The 1991 General Assembly, at the request of chief patron Delegate Mary T. Christian (D/Hampton), passed House Joint-Resolution 473, requesting the Department of Education to study the safety of school playground equipment.

STATEMENT OF NEED/PROBLEM:

To study the safety of school playground equipment.

SPECIFIC OBJECTIVE:

- A) Undertake a review of the types of playground equipment in use by the public schools and the age range of the children for whom such equipment was purchased;
- B) Determine the number of children hurt in playground accidents each year, the types of injury, the causes of such accidents, and whether such incidents are required to be reported to the division superintendent and local or state health officials;
- C) Review the initiatives in other states to establish safety standards for school playgrounds and equipment, and the safety standards desired by professional medical and educational associations and interested consumer groups;
- D) Identify the primary manufacturers of playground equipment and whether there are any federal regulations and standards, manufacturer's internal quality control standards, or guidelines for the construction, quality, and safety of playground equipment established by a recognized association of the manufacturers of playground equipment to which such manufacturers must adhere; and

RFP- Request for Proposal # _____

Virginia Department of Education

- E) Determine the need, if any, for statewide standards to ensure the safety of school playgrounds and equipment, the age appropriateness of such equipment, and regulations or guidelines for this repair and replacement of broken and obsolete equipment.

REQUIRED DELIVERABLES/PRODUCTS:

A report must be developed including the stated objectives and must be completed for a August 1, 1991, review by the Department of Education Management Group. This report must be written following the format requirements (attached) of the Division of Legislative Automated Systems.

LIMITATIONS:

- . No more than 10 staff days to be allocated.
- . Strong consideration should be given to the fact that this has been a traditional local concern.

SEE ATTACHED IDEA FORM FOR ADDITIONAL INFORMATION

RESPONSES ARE DUE TO DEBBIE ELLISON ON: April 24, 1991

AWARD WILL BE MADE ON: No later than May 8, 1991

GENERAL ASSEMBLY OF VIRGINIA--1991 SESSION

HOUSE JOINT RESOLUTION NO. 473

Requesting the Department of Education to study the safety of school playground equipment.

Agreed to by the House of Delegates, February 4, 1991

Agreed to by the Senate, February 21, 1991

WHEREAS, physical activity is an integral part of a child's day and essential to his growth and development; and

WHEREAS, § 22.1-207 of the Code of Virginia requires that "physical education be emphasized throughout the public school curriculum by lessons, drills and physical exercises," and children in the elementary grades often use playground equipment as a part of such instruction and during recess periods; and

WHEREAS, although much school playground equipment is donated, lessening the costs for such items to local school boards, large sums are spent to purchase playground equipment, particularly for newly constructed schools; and

WHEREAS, the control of school playground equipment is the responsibility of the local school board, and there are no state regulations or guidelines that establish standards for school playgrounds; and

WHEREAS, much school playground equipment may be obsolete, worn out, in disrepair or inappropriate for young children, and an inventory of the condition of such equipment has never been conducted; and

WHEREAS, although numerous children are hurt each year in playground accidents, there are no standards for playground equipment or guidelines for the repair and replacement of old and broken equipment; and

WHEREAS, because it is important to ensure that the equipment on which young children play is safe and age appropriate, serious consideration should be given to establishing standards to ensure the safety of playground equipment and regulations and guidelines to require the repair of broken equipment and the timely replacement of obsolete and worn equipment; now, therefore, be it

RESOLVED by the House of Delegates, the Senate concurring, That the Department of Education be requested to study the safety of school playground equipment.

The Department shall (i) undertake a review of the types of playground equipment in use by the public schools and the age range of the children for whom such equipment was purchased; (ii) determine the number of children hurt in playground accidents each year, the types of injury, the causes of such accidents, and whether such incidents are required to be reported to the division superintendent and local or state health officials; (iii) review the initiatives in other states to establish safety standards for school playgrounds and equipment, and the safety standards desired by professional medical and educational associations and interested consumer groups; (iv) identify the primary manufacturers of playground equipment and whether there are any federal regulations and standards, manufacturer's internal quality control standards, or guidelines for the construction, quality, and safety of playground equipment established by a recognized association of the manufacturers of playground equipment to which such manufacturers must adhere; and (v) determine the need for statewide standards to ensure the safety of school playgrounds and equipment, the age appropriateness of such equipment, and regulations or guidelines for the repair and replacement of broken and obsolete equipment.

The Department shall complete its work in time to submit its findings and recommendations to the Governor and the 1992 Session of the General Assembly as provided in the procedures of the Division of Legislative Automated Systems for the processing of legislative documents.

Appendix C

Early Childhood Proposal for RFP 91-29

RFP - Request for Proposal # 91-29

Virginia Department of Education

1. Summary of Approach Proposed

It is the perception that numerous school age students are injured on school playgrounds each year. While some injuries may be the result of careless "child's play," other injuries may occur due to improper playground equipment. In order to determine the degree to which this may be true, the Early Childhood Division of the Student Services Unit proposes to study the safety of school playground equipment in the Commonwealth of Virginia. This study would also respond to House Joint Resolution 473 which raises the question of the safety of playground equipment and requests the Department of Education to conduct such a study.

The study will consist of two phases. Phase one will be a period of information/data collection. Phase two will review and analyze the results of phase one culminating in a report which addresses the requirements of the study including recommendations for the need for statewide standards. Furthermore, the compiled results will be examined to determine whether there is a need to establish statewide guidelines to ensure the safety of school playgrounds and equipment, the age appropriateness of such equipment, and regulations or guidelines for the repair and replacement of broken and obsolete equipment. The accumulated information and the resulting recommendations will be presented, in a written report, to the Department of Education Management Team by August 1, 1991.

2. Implementation Plan/Methodology

Using the objective of RFP 91-29 as a framework, the project team will undertake a series of data collection activities to produce the data base used in the analysis.

Objectives of RFP 91-29:

- A. Undertake a review of the types of playground equipment in use by the public schools and the age range of the children for whom such equipment was purchased;
- B. Determine the number of children hurt in playground accidents each year, the types of injury, the causes of such accidents, and whether such

incidents are required to be reported to the division superintendent and local or state health officials;

- C. Review the initiatives in other states to establish safety standards for school playgrounds and equipment, and the safety standards desired by professional medical and education associations and interested consumer groups;
- D. Identify the primary manufacturers of playground equipment and whether there are any federal regulations and standards, manufacturer's internal quality control standards, or guidelines for the construction, quality, and safety of playground equipment established by a recognized association of the manufacturers of playground equipment to which such manufacturer must adhere; and
- E. Determine the need, if any, for statewide standards to ensure the safety of school playgrounds and equipment, the age appropriateness of such equipment, and regulations or guidelines for this repair and replacement of broken and obsolete equipment.

Activities/Tasks	Objectives				
	<u>A</u>	<u>B</u>	<u>C</u>	<u>D</u>	<u>E</u>
1. Review current existing literature outlined on an ERIC search of articles concerning playground safety			X		
2. Review playground safety standards conducted by the National Association for the Education of Young Children		X			
3. Contact the American Academy of Pediatrics for any pertinent documents concerning injuries on playgrounds		X			
4. Contact the University of Virginia and the Medical College of Virginia health information centers for information concerning childhood injuries on playgrounds		X			
5. Contact the Virginia Commonwealth University School for Environmental	X				

Activities/Tasks	Objectives				
	<u>A</u>	<u>B</u>	<u>C</u>	<u>D</u>	<u>E</u>
5. (contd.) Health and Safety concerning studies on playground injuries and safety					
6. Contact the National Safety Council for patterns of incidents/accidents occurring on playground equipment and for any recommendations pertaining to playground equipment guidelines				X	
7. Contact the Department of Social Services regarding minimum standards for licensed			X		
8. Contact the Consumer Product Safety Commission concerning national information statistics about playground injuries					X
9. Develop and utilize a survey to principals of elementary schools. This survey will request information on playground equipment, playground related injuries, and procedures for reporting injuries. The results of the survey will be compiled and reviewed for determining possible trends	X	X			
10. Review Sweets Catalogue of Architectural Engineering Products to determine major manufacturers of playground equipment and alternative resilient surfaces				X	
11. Review the list of distributors of playground equipment and resilient surfaces which have exhibits at the American Alliance of Health, Physical Education, Recreation and Dance Conference and the National Association of Young Children Conference. Compare these lists with those manufacturers included in Sweets Catalogue of Architectural Engineering Products				X	

Activities/Tasks	Objectives				
	<u>A</u>	<u>B</u>	<u>C</u>	<u>D</u>	<u>E</u>
12. Contact the National Bureau of Standards to determine if national guidelines do exist for the manufacturing of playground equipment			X		
13. Contact the Consumer Reports on off-prints they have on playground equipment	X				
14. Review playground safety guidelines that have been developed by local school divisions	X				
15. Review those states' standards which are identified by the American Alliance of Health, Physical Education, Recreation and Dance as having initiatives concerning guidelines/safety standards			X		
16. Coordinate the project team analysis with a related effort underway by the Virginia Physical Education City and County Supervisors' Committee on Playground Safety	X				
17. Contact the Department of Conservation and Recreation to determine any guidelines it may have for its playground equipment					

The information collected as a result of these procedures will be analyzed to determine whether there is a need to establish statewide guidelines to ensure the safety of school playgrounds and equipment, the age appropriateness of such equipment, and regulations or guidelines for the repair and replacement of broken and obsolete equipment (objective E). The accumulated information and the resulting recommendations will be presented, in a written report, according to JLARC requirements, to the Department of Education Management Team by August 1, 1991

3. Deliverables

As specified in the RFP, a final report addressing the objectives of HJR 473 will be prepared according to JLARC processing guidelines. A preliminary report will be submitted to agency management for review and critique prior to the August 1, 1991, deadline established by the RFP.

4. Timelines

May 8 - 15, 1991	Develop Survey
May 15 - July 5, 1991	Data Collection
May 15 - July 12, 1991	Data Analysis
Early July - July 15, 1991	Preparation of Preliminary Report for Department of Education Management Team
July 19 - 31, 1991	Preparation of Final Report of Education Management Team and General Assembly
August 1, 1991	Final report submitted to the Department of Education Management Team

	May 8 - 15	June 1 - 15	July 1 - 15	August 1
Phase One - Data Collection	x-----	-----x		
Phase Two - Data Analysis		x-----	-----x	
Preliminary Report			x	
Final Report				x

5. Budget

<u>Item</u>	<u>Cost</u>
80/120 hours in-kind staff time (detailed below)	
Postage	\$50.00
ERIC Search and Documents	\$100.00
Printing/Reproduction, Supplies	\$100.00
Total Dollars	\$250.00

Note: The time limitation of ten days for this project is believed to be an underestimate of the time required to produce a quality study and report. An alternative suggested timeframe for project completion is detailed in section 5 (Budget). However, if the Management Team adheres to the 10-day allowance, project activities will be modified to meet this requirement with the understanding that the quality and /or completeness of the final report will be necessarily impacted.

6. Stakeholders/Intended Audience

- a. Elementary school students of Virginia public schools
- b. School administrators
- c. School boards
- d. General Assembly members of HJR 473
(Delegate Mary T. Christian, Chief Patron)

7. Evaluation Plan

The evaluation of the playground equipment safety study will be based upon four factors. These are:

The thoroughness of developing and obtaining quantitative and qualitative data for each one of the areas described within the five (5) objectives.

The number of different productive sources the team is able to access in its investigation within the time constraints as described by the RFP.

The ability of the study team to produce the report prior to the assigned deadline.

The level of editing and re-investigation that must occur after the management team reviews the initial findings.

Appendix D

Letters Concerning Consultants' Assistance



COMMONWEALTH of VIRGINIA

DEPARTMENT OF EDUCATION

P.O. BOX 6-0

RICHMOND 23216-2060

June 3, 1991

Ms. Liz Campbell
Department of Social Services
Division of Licensing Programs
8007 Discovery Drive
Richmond, VA 23229

Dear Ms. Campbell:

On behalf of the playground safety team, I would like to thank you for sharing with us your expertise regarding playground safety. The information that you gave to the team will assist us in accomplishing our goal to conduct a comprehensive playground study in the Commonwealth. Moreover, the insights that you provided will enable us to make more inclusive recommendations in response to House Joint Resolution No. 473.

I am including a copy of the surveys which will be sent out this week in a Superintendent's memo. As you can see, both surveys reflect suggestions that you made!

I look forward to continuing to work with you on behalf of the safety of children throughout the Commonwealth. I will keep in touch regarding our progress with the playground safety study. Also, please feel free to contact me concerning questions or assistance.

Sincerely,

Valerie H. Barrett
Associate Specialist - Gifted Programs
Early Childhood Division

Enclosures

CC: M. Jo Bunce - Division Chief, Early Childhood Education
Department of Education



COMMONWEALTH of VIRGINIA

DEPARTMENT OF EDUCATION

P.O. BOX 6-Q

RICHMOND 23216-2060

June 3, 1991

Ms. Jeanne Saunders, RN, MSN
Medical College of Virginia
Children's Medical Center
Box 522
MCV Station
Richmond, VA 23298-0522

Dear Ms. Saunders:

On behalf of the playground safety team, I would like to thank you for sharing with us your expertise regarding playground safety. The information that you gave to the team will assist us in accomplishing our goal to conduct a comprehensive playground study in the Commonwealth. Moreover, the insights that you provided will enable us to make more inclusive recommendations in response to House Joint Resolution No. 473.

I am including a copy of the surveys which will be sent out this week in a Superintendent's memo. As you can see, both surveys reflect suggestions that you made!

I look forward to continuing to work with you on behalf of the safety of children throughout the Commonwealth. I will keep in touch regarding our progress with the playground safety study. Also, please feel free to contact me concerning questions or assistance.

Sincerely,

Valerie H. Barrett
Associate Specialist - Gifted Programs
Early Childhood Division

Enclosures

CC: Dr. Joseph Zanga, MD, SAAAP
Medical College of Virginia

M. Jo Bunce - Division Chief, Early Childhood Education
Department of Education



Medical College of Virginia
Virginia Commonwealth University

June 11, 1991

Valerie H. Barrett
Associate Specialist-Gifted Programs
Early Childhood Division
Department of Education
P.O. Box 6-Q
Richmond, Virginia 23216-2060

Dear Mrs. Barrett:

Thank you for sending us a copy of the surveys developed by the playground safety team. We would be very grateful if you would send us a copy of the survey results as well as a copy of your recommendations to the General Assembly based on those results. The information will be very useful to us in the continued development of our playground safety program.

Sincerely.

Jeanne K. Sanders, RN, MSN
Coordinator Childhood
Injury Prevention Program

Joseph R. Zanga, MD
Chairman Division of General
Pediatrics and Emergency
Care

JKS-JRZ/czc

Appendix E

Superintendent's Memo No. 53 - Division Surveys

COMMONWEALTH OF VIRGINIA
DEPARTMENT OF EDUCATION
P. O. BOX 6Q
RICHMOND, VIRGINIA 23216-2060

SUPTS. MEMO. NO. 53
June 5, 1991

ADMINISTRATIVE

TO: Division Superintendents

FROM: Joseph A. Spagnolo, Jr.
Superintendent of Public Instruction

Ida J. Hill
Deputy Superintendent for Student Services

SUBJECT: Playground Safety Information Requests

During the 1991 Session, the Virginia General Assembly passed House Joint Resolution 473 (copy enclosed) requesting the Virginia Department of Education to conduct a study of school playground safety. Part of the information that was requested is a determination of the number, types, and causes of accidents occurring on public schools' playgrounds of the Commonwealth each year. In addition, the resolution calls for a review of the requirements for reporting the accidents within school divisions and to local and state health officials.

In order to gain the information that the General Assembly has requested, the Department is asking that each division superintendent or his/her designee complete the enclosed information sheet and return it by August 16, 1991 to:

Mrs. Valerie Barrett
Department of Education
Early Childhood Student Services Division - 20th Floor
P. O. Box 6Q
Richmond, Virginia 23216-2060

Another survey is being sent to the principals of the enclosed list of elementary schools in the Commonwealth. This survey also requests information that is required in response to House Joint Resolution 473. A copy of this survey is enclosed for your review.

If you have any questions or comments, please call Mrs. Barrett at (804) 225-2652.

JAS,Jr./IJH/pl

Enclosures

1991 SESSION

LD9196434

1 **HOUSE JOINT RESOLUTION NO. 473**
2 **AMENDMENT IN THE NATURE OF A SUBSTITUTE**
3 (Proposed by the House Committee on Rules
4 on February 2, 1991)

5 (Patron Prior to Substitute—Delegate Christian)

6 *Requesting the Department of Education to study the safety of school playground*
7 *equipment.*

8 WHEREAS, physical activity is an integral part of a child's day and essential to his
9 growth and development; and

10 WHEREAS, § 22.1-207 of the Code of Virginia requires that "physical education be
11 emphasized throughout the public school curriculum by lessons, drills and physical
12 exercises," and children in the elementary grades often use playground equipment as a
13 part of such instruction and during recess periods; and

14 WHEREAS, although much school playground equipment is donated, lessening the costs
15 for such items to local school boards, large sums are spent to purchase playground
16 equipment, particularly for newly constructed schools; and

17 WHEREAS, the control of school playground equipment is the responsibility of the local
18 school board, and there are no state regulations or guidelines that establish standards for
19 school playgrounds; and

20 WHEREAS, much school playground equipment may be obsolete, worn out, in disrepair
21 or inappropriate for young children, and an inventory of the condition of such equipment
22 has never been conducted; and

23 WHEREAS, although numerous children are hurt each year in playground accidents,
24 there are no standards for playground equipment or guidelines for the repair and
25 replacement of old and broken equipment; and

26 WHEREAS, because it is important to ensure that the equipment on which young
27 children play is safe and age appropriate, serious consideration should be given to
28 establishing standards to ensure the safety of playground equipment and regulations and
29 guidelines to require the repair of broken equipment and the timely replacement of
30 obsolete and worn equipment; now, therefore, be it

31 RESOLVED by the House of Delegates, the Senate concurring, That the Department of
32 Education be requested to study the safety of school playground equipment.

33 The Department shall (i) undertake a review of the types of playground equipment in
34 use by the public schools and the age range of the children for whom such equipment was
35 purchased; (ii) determine the number of children hurt in playground accidents each year,
36 the types of injury, the causes of such accidents, and whether such incidents are required
37 to be reported to the division superintendent and local or state health officials; (iii) review
38 the initiatives in other states to establish safety standards for school playgrounds and
39 equipment, and the safety standards desired by professional medical and educational
40 associations and interested consumer groups; (iv) identify the primary manufacturers of
41 playground equipment and whether there are any federal regulations and standards,
42 manufacturer's internal quality control standards, or guidelines for the construction, quality,
43 and safety of playground equipment established by a recognized association of the
44 manufacturers of playground equipment to which such manufacturers must adhere; and (v)
45 determine the need for statewide standards to ensure the safety of school playgrounds and
46 equipment, the age appropriateness of such equipment, and regulations or guidelines for the
47 repair and replacement of broken and obsolete equipment.

48 The Department shall complete its work in time to submit its findings and
49 recommendations to the Governor and the 1991 General Assembly as provided in the
50 procedures of the Division of Legislative Automated Systems for processing legislative
51 documents.

52

53

54

**ELEMENTARY SCHOOL PRINCIPAL SURVEY
PLAYGROUND SAFETY STUDY**

<u>Division</u>	<u>School</u>
Albemarle	Murray Alternative
Amelia	Amelia
Augusta	Wilson
Bedford	Thaxton
Botetourt	Eagle Rock
Bristol	Stonewall Jackson
Brunswick	Meherrin Powellton
Buchanan	Vansant
Buena Vista	Enderly Heights
Carroll	Oakland
Charles City	Charles City
Charlotte	Eureka
Charlottesville	Johnson
Clarke	D. G. Cooley
Colonial Heights	Tussing
Covington	Edgemont
Culpeper	Pearl Sample
Danville	Woodberry
Essex	Tappahannock
Falls Church	Thomas Jefferson
Fauquier	Coleman
Fluvanna	Cunningham
Galax	Galax
Gloucester	Petsworth
Goochland	Byrd
Grayson	Independence
Greensville	Zion
Hanover	South Anna
Harrisonburg	Spotswood
Hopewell	Dupont
King & Queen	King & Queen
Lunenburg	Lunenburg
Madison	Madison
Manassas	Weems
Martinsville	Druid
Nelson	Ryan
New Kent	New Kent
Norfolk	St. Mary's Infant Home
Northampton	Exmore-Willis Wharf
Petersburg	Westview
Pittsylvania	Union Hall
Prince William	New Dominion
Radford	Belle Heth
Rockingham	Pleasant Valley
Salem	West Salem
Scott	Weber City
South Boston	Washington Coleman

Elementary School Principal Survey
Page 2

Division

Spotsylvania
Staunton
Va. Beach
Westmoreland
Williamsburg
Wise
York

School

Spotswood
Thomas C. McSwain
Old Donation
Cople
Rawls Byrd
St. Paul
Yorktown

Elementary School Playground Safety Information Request

Survey of Principals

School _____ School Division _____

School's Address _____

Telephone No. (____) _____ Person Responding/Title _____

Grade Levels Housed _____ School Enrollment _____

1. Check all which are applicable for your school's outside play area facilities.

- My school has a basic outside play area. The equipment located at this play area serves all students attending my school.
- My school has a separate outside play area for K-2 students. The equipment located at this play area was selected because it is age appropriate.
- My school has a separate outside play area for 3-7 students. The equipment located at this play area was selected because it is age appropriate.
- My school does not have an outside play area which includes playground equipment.

2. Complete the following chart in accordance with the equipment present on your school's playground facilities. Place a check in the appropriate column(s). Indicate whether the equipment is predominately wood (W), metal (M), or plastic (P) by placing a check in the appropriate space.

Equipment	<u>COMPOSITION</u>				<u>COMPOSITION</u>				<u>COMPOSITION</u>			
	<u>Pre-K-2</u>	<u>W</u>	<u>M</u>	<u>P</u>	<u>3-7</u>	<u>W</u>	<u>M</u>	<u>P</u>	<u>Pre-K-7</u>	<u>W</u>	<u>M</u>	<u>P</u>
sliding board	_____	_____	_____	_____	_____	_____	_____	_____	_____	_____	_____	_____
merry-go-round	_____	_____	_____	_____	_____	_____	_____	_____	_____	_____	_____	_____
see-saw	_____	_____	_____	_____	_____	_____	_____	_____	_____	_____	_____	_____
swing (regular)	_____	_____	_____	_____	_____	_____	_____	_____	_____	_____	_____	_____
swing (tire)	_____	_____	_____	_____	_____	_____	_____	_____	_____	_____	_____	_____
climbing apparatus	_____	_____	_____	_____	_____	_____	_____	_____	_____	_____	_____	_____
horizontal ladder	_____	_____	_____	_____	_____	_____	_____	_____	_____	_____	_____	_____
chinning bar	_____	_____	_____	_____	_____	_____	_____	_____	_____	_____	_____	_____
fireman's pole	_____	_____	_____	_____	_____	_____	_____	_____	_____	_____	_____	_____
trapeze & rings	_____	_____	_____	_____	_____	_____	_____	_____	_____	_____	_____	_____
other _____	_____	_____	_____	_____	_____	_____	_____	_____	_____	_____	_____	_____
other _____	_____	_____	_____	_____	_____	_____	_____	_____	_____	_____	_____	_____
other _____	_____	_____	_____	_____	_____	_____	_____	_____	_____	_____	_____	_____

3. Check whether the playground equipment is either free-standing or interconnected for the outside play areas located at your school.

<u>Outside Play Area(s)</u>	<u>Free-Standing</u>	<u>Interconnected</u>	<u>Some of Each Type</u>
K-2	_____	_____	_____
3-7	_____	_____	_____
K-7	_____	_____	_____

4. Check which type(s) of surface is located underneath your playground equipment.

grass dirt sand wood chips/mulch concrete/asphalt
 shredded rubber gravel synthetic mat other _____

5. Does your playground have any equipment that is specifically designed for children with disabilities?

Yes No

6. If an injury occurs on your playground that requires professional medical attention, check all of the following actions you are required to take:

- I am required to report injuries requiring professional medical attention to my superintendent.
- I am required to report injuries requiring professional medical attention to local health department officials.
- I am required to report injuries requiring professional medical attention to state health officials.
- I am not required to report these injuries to anyone but I am required to document injuries.
- I am not required to report these injuries to anyone and injuries are not documented.

7. Have you planned a review of your playground equipment or taken any other action because of the new standards which have been developed and adopted by the U. S. Consumer Product Safety Commission?

Yes No

8. Is there a need for such uniform, research-based standards to ensure:

- | | | |
|--|------------------------------|-----------------------------|
| Safety of school playgrounds and equipment? | <input type="checkbox"/> Yes | <input type="checkbox"/> No |
| Age appropriateness of such equipment? | <input type="checkbox"/> Yes | <input type="checkbox"/> No |
| The repair and replacement of broken and obsolete equipment? | <input type="checkbox"/> Yes | <input type="checkbox"/> No |

Division-wide Playground Safety Information Request
Division Central Office Survey

School Division _____

Person Responding/Title _____

Address _____

Telephone Number (_____) _____

1. **Number of playground accidents requiring professional medical attention occurring in your school division during the following years:**

If any of the requested information is not available, please indicate "N.A."

	Number of Accidents
1990 - 1991 School Year	_____
1989 - 1990 School Year	_____
1988 - 1989 School Year	_____
1987 - 1988 School Year	_____

2. **Approximate number of accidents by type (for the last year you have complete information).**

Abrasions, Cuts, or Puncture Wounds _____

Eye Injuries _____

Sprains/Strains _____

Broken Bones _____

Head Injuries _____

Other (Describe) _____

3. Approximate number of accidents by cause (for the last year you have complete information).

Falls from Equipment	_____
Impact with Moving Equipment	_____
Bumping into Stationary Equipment	_____
Contact with Protrusions, Sharp Edges, or Pinchpoints	_____
Entanglement/Entrapment	_____
Equipment Tipover	_____
Equipment Failure	_____
Playground Debris	_____
Other _____	_____

4. Has your division planned a review of your playground equipment or taken any other action because of the new standards which have been developed and adopted by the U. S. Consumer Product Safety Commission?

_____ Yes _____ No

5. Is there a need for such uniform, research-based standards to ensure:

Safety of school playgrounds and equipment?	_____ Yes	_____ No
Age appropriateness of such equipment?	_____ Yes	_____ No
The repair and replacement of broken and obsolete equipment?	_____ Yes	_____ No

6. Does your division have a requirement for such accidents to be reported to:

Division superintendent?	_____ Yes	_____ No
Local health officials?	_____ Yes	_____ No
State health officials?	_____ Yes	_____ No

7. What is the number of students enrolled in schools which have playgrounds?

8. Do you (or a contractee using any of your school sites) operate child-care or extended-day programs before or after school? If so, please answer the following questions. If not, write "N.A." in the blanks.

How many schools in your school division are sites for extended-day programs which are operated before and/or after school?

How how many children are served at the combined sites?

Appendix F

Elementary School Survey



COMMONWEALTH of VIRGINIA

DEPARTMENT OF EDUCATION

P. O. BOX 6-Q

RICHMOND 23216-2060

June 17, 1991

TO: Selected Elementary Principals
FROM: The Playground Safety Study Team
SUBJECT: Playground Safety Information Request

During the 1991 Session, the Virginia General Assembly passed **House Joint Resolution 473** (copy enclosed) requesting the Virginia Department of Education to conduct a study of school playground safety. Part of the information that was requested concerns the variety of playground equipment located on school playgrounds around the Commonwealth and playground injury reporting procedures which are utilized.

In order to gain the information that the General Assembly has requested, the Department is asking that principals of elementary schools on the Student Services Division spring visitation list, or their designee, complete the enclosed survey and return it by August 16, 1991 to:

Mrs. Valerie Barrett
Department of Education
Early Childhood Student Services Division - 20th Floor
P. O. Box 6Q
Richmond, Virginia 23216-2060

Another survey, which is designed to obtain different information, has been sent for completion by all superintendents in Virginia, along with a copy of the survey that has been sent to you. Therefore, your superintendent is aware that this information has been requested from you.

If you have any questions, please call Mrs. Barrett at (804) 225-2652.

1991 SESSION

LD9196434

1 **HOUSE JOINT RESOLUTION NO. 473**
2 **AMENDMENT IN THE NATURE OF A SUBSTITUTE**
3 (Proposed by the House Committee on Rules
4 on February 2, 1991)
5 (Patron Prior to Substitute—Delegate Christian)

6 *Requesting the Department of Education to study the safety of school playground*
7 *equipment.*

8 WHEREAS, physical activity is an integral part of a child's day and essential to his
9 growth and development; and

10 WHEREAS, § 22.1-207 of the Code of Virginia requires that "physical education be
11 emphasized throughout the public school curriculum by lessons, drills and physical
12 exercises," and children in the elementary grades often use playground equipment as a
13 part of such instruction and during recess periods; and

14 WHEREAS, although much school playground equipment is donated, lessening the costs
15 for such items to local school boards, large sums are spent to purchase playground
16 equipment, particularly for newly constructed schools; and

17 WHEREAS, the control of school playground equipment is the responsibility of the local
18 school board, and there are no state regulations or guidelines that establish standards for
19 school playgrounds; and

20 WHEREAS, much school playground equipment may be obsolete, worn out, in disrepair
21 or inappropriate for young children, and an inventory of the condition of such equipment
22 has never been conducted; and

23 WHEREAS, although numerous children are hurt each year in playground accidents,
24 there are no standards for playground equipment or guidelines for the repair and
25 replacement of old and broken equipment; and

26 WHEREAS, because it is important to ensure that the equipment on which young
27 children play is safe and age appropriate, serious consideration should be given to
28 establishing standards to ensure the safety of playground equipment and regulations and
29 guidelines to require the repair of broken equipment and the timely replacement of
30 obsolete and worn equipment; now, therefore, be it

31 RESOLVED by the House of Delegates, the Senate concurring, That the Department of
32 Education be requested to study the safety of school playground equipment.

33 The Department shall (i) undertake a review of the types of playground equipment in
34 use by the public schools and the age range of the children for whom such equipment was
35 purchased; (ii) determine the number of children hurt in playground accidents each year,
36 the types of injury, the causes of such accidents, and whether such incidents are required
37 to be reported to the division superintendent and local or state health officials; (iii) review
38 the initiatives in other states to establish safety standards for school playgrounds and
39 equipment, and the safety standards desired by professional medical and educational
40 associations and interested consumer groups; (iv) identify the primary manufacturers of
41 playground equipment and whether there are any federal regulations and standards,
42 manufacturer's internal quality control standards, or guidelines for the construction, quality,
43 and safety of playground equipment established by a recognized association of the
44 manufacturers of playground equipment to which such manufacturers must adhere; and (v)
45 determine the need for statewide standards to ensure the safety of school playgrounds and
46 equipment, the age appropriateness of such equipment, and regulations or guidelines for the
47 repair and replacement of broken and obsolete equipment.

48 The Department shall complete its work in time to submit its findings and
49 recommendations to the Governor and the 1991 General Assembly as provided in the
50 procedures of the Division of Legislative Automated Systems for processing legislative
51 documents.

52
53
54

**ELEMENTARY SCHOOL PRINCIPAL SURVEY
PLAYGROUND SAFETY STUDY**

<u>Division</u>	<u>School</u>
Albemarle	Murray Alternative
Amelia	Amelia
Augusta	Wilson
Bedford	Thaxton
Botetourt	Eagle Rock
Bristol	Stonewall Jackson
Brunswick	Meherrin Powellton
Buchanan	Vansant
Buena Vista	Enderly Heights
Carroll	Oakland
Charles City	Charles City
Charlotte	Eureka
Charlottesville	Johnson
Clarke	D. G. Cooley
Colonial Heights	Tussing
Covington	Edgemont
Culpeper	Pearl Sample
Danville	Woodberry
Essex	Tappahannock
Falls Church	Thomas Jefferson
Fauquier	Coleman
Fluvanna	Cunningham
Galax	Galax
Gloucester	Petsworth
Goochland	Byrd
Grayson	Independence
Greensville	Zion
Hanover	South Anna
Harrisonburg	Spotswood
Hopewell	Dupont
King & Queen	King & Queen
Lunenburg	Lunenburg
Madison	Madison
Manassas	Weems
Martinsville	Druid
Nelson	Ryan
New Kent	New Kent
Norfolk	St. Mary's Infant Home
Northampton	Exmore-Willis Wharf
Petersburg	Westview
Pittsylvania	Union Hall
Prince William	New Dominion
Radford	Belle Heth
Rockingham	Pleasant Valley
Salem	West Salem
Scott	Weber City
South Boston	Washington Coleman

Elementary School Principal Survey

Page 2

Division

Spotsylvania
Staunton
Va. Beach
Westmoreland
Williamsburg
Wise
York

School

Spotswood
Thomas C. McSwain
Old Donation
Cople
Rawls Byrd
St. Paul
Yorktown

Elementary School Playground Safety Information Request

Survey of Principals

School _____

School Division _____

School's Address _____

Telephone No. (____) _____

Person Responding/Title _____

Grade Levels Housed _____

School Enrollment _____

1. **Check all which are applicable for your school's outside play area facilities.**

My school has a basic outside play area. The equipment located at this play area serves all students attending my school.

My school has a separate outside play area for K-2 students. The equipment located at this play area was selected because it is age appropriate.

My school has a separate outside play area for 3-7 students. The equipment located at this play area was selected because it is age appropriate.

My school does not have an outside play area which includes playground equipment.

2. Complete the following chart in accordance with the equipment present on your school's playground facilities. Place a check in the appropriate column(s). Indicate whether the equipment is predominately wood (W), metal (M), or plastic (P) by placing a check in the appropriate space.

Equipment	COMPOSITION				COMPOSITION				COMPOSITION			
	Pre-K-2	W	M	P	3-7	W	M	P	Pre-K-7	W	M	P
sliding board	_____	_____	_____	_____	_____	_____	_____	_____	_____	_____	_____	_____
merry-go-round	_____	_____	_____	_____	_____	_____	_____	_____	_____	_____	_____	_____
see-saw	_____	_____	_____	_____	_____	_____	_____	_____	_____	_____	_____	_____
swing (regular)	_____	_____	_____	_____	_____	_____	_____	_____	_____	_____	_____	_____
swing (tire)	_____	_____	_____	_____	_____	_____	_____	_____	_____	_____	_____	_____
climbing apparatus	_____	_____	_____	_____	_____	_____	_____	_____	_____	_____	_____	_____
horizontal ladder	_____	_____	_____	_____	_____	_____	_____	_____	_____	_____	_____	_____
chinning bar	_____	_____	_____	_____	_____	_____	_____	_____	_____	_____	_____	_____
fireman's pole	_____	_____	_____	_____	_____	_____	_____	_____	_____	_____	_____	_____
trapeze & rings	_____	_____	_____	_____	_____	_____	_____	_____	_____	_____	_____	_____
other _____	_____	_____	_____	_____	_____	_____	_____	_____	_____	_____	_____	_____
other _____	_____	_____	_____	_____	_____	_____	_____	_____	_____	_____	_____	_____
other _____	_____	_____	_____	_____	_____	_____	_____	_____	_____	_____	_____	_____

3. Check whether the playground equipment is either free-standing or interconnected for the outside play areas located at your school.

Outside Play Area(s)	Free-Standing	Interconnected	Some of Each Type
K-2	_____	_____	_____
3-7	_____	_____	_____
K-7	_____	_____	_____

4. Check which type(s) of surface is located underneath your playground equipment.

grass dirt sand wood chips/mulch concrete/asphalt
 shredded rubber gravel synthetic mat other _____

5. Does your playground have any equipment that is specifically designed for children with disabilities?

Yes No

6. If an injury occurs on your playground that requires professional medical attention, check all of the following actions you are required to take:

- I am required to report injuries requiring professional medical attention to my superintendent.
 I am required to report injuries requiring professional medical attention to local health department officials.
 I am required to report injuries requiring professional medical attention to state health officials.
 I am not required to report these injuries to anyone but I am required to document injuries.
 I am not required to report these injuries to anyone and injuries are not documented.

7. Have you planned a review of your playground equipment or taken any other action because of the new standards which have been developed and adopted by the U. S. Consumer Product Safety Commission?

Yes No

8. Is there a need for such uniform, research-based standards to ensure:

- Safety of school playgrounds and equipment? Yes No
Age appropriateness of such equipment? Yes No
The repair and replacement of broken and obsolete equipment? Yes No

Appendix G

**Survey to Physical
Education Directors at State
Education Agencies
throughout the U. S.**



COMMONWEALTH of VIRGINIA

DEPARTMENT OF EDUCATION
P.O. BOX 6-Q
RICHMOND 23216-2060

June 18, 1991

Appendix III E
Chapter III

Mr. Gerald Christensen
Kansas State Board of Education
120 East 10th Street
Topeka, Kansas 66612-1103

Dear Mr. Christensen:

During the 1991 Session, the Virginia General Assembly passed a Joint Resolution 473 requesting the Virginia Department of Education to study school playground safety. This study will enable the Department of Education to determine whether there is a need for state guidelines concerning school playground equipment and to make a recommendation accordingly.

As part of the study, the General Assembly has requested that the Department of Education determine whether other states have established guidelines for playground equipment. In this endeavor, I am requesting that you complete the attachment indicating whether Kansas has established such guidelines and return it to me by August 1, 1991. If guidelines have been established, it would be most helpful if you could send a copy of the guidelines along with the attachment.

I thank you in advance for your assistance with this study of playground safety.

Sincerely,

Valerie Barrett
Associate Specialist
Early Childhood Education

CC: Mrs. M. Jo Bunce, Division Chief
Virginia Department of Education

**COMMONWEALTH OF VIRGINIA
DEPARTMENT OF EDUCATION
INFORMATION REQUEST
STATE GUIDELINES FOR SCHOOL PLAYGROUND EQUIPMENT**

State _____

Person Responding/Title _____

Phone Number (_____)_____

Check the appropriate space(s):

----- **My state does not have guidelines concerning school playground equipment.**

----- **My state does have guidelines concerning school playground equipment.**

----- **My state's guidelines are mandated by legislature.**

----- **A copy of my state's guidelines concerning school playground equipment is enclosed.**

Comments _____

Return by August 1, 1991 to:

**Mrs. Valerie Barrett
Commonwealth of Virginia
Department of Education
Early Childhood Student Services Division - 20th Floor**

Appendix H

ERIC Search of Literature Concerning Playground Safety

Appendix I

Virginia Physical Education City and County Supervisors' Committee on Playground Safety

Playground Committee

The following individuals have been involved with the V.D.O.E. in discussing guidelines etc. for playground safety.

Dr. Robert Turner, Averett College - Danville, VA
John Millard, Principal, West Salem Elementary - Salem City
John Hurst, Supervisor Health & P.E. - Richmond City
Dr. Diana Dixon, Principal, Colonial Elementary - Botetourt County
Marilyn Bray, Supervisor Health & P.E. - Chesterfield County
Gary Martin, Supervisor Health & P.E. - Prince William County
Jim Stout, Supervisor Health & P.E. - Augusta County
Jack Liddy, Supervisor Health & P.E. - Roanoke County
Howard Light, Supervisor Health & P.E. - Roanoke City Schools
Jane Painter, Teacher & Supervisor of Health & P.E. - Salem City
Kay Duffy, Principal, Woodrow Wilson Jr. High - Roanoke City
Wayne Motley, Assistant Director Elementary Ed. - Hanover County

These are some statements they feel we should include in a guide, brochure, etc.

1. When selecting playground equipment for school programs the focus should be on the promotion of fitness and physical education objectives.
2. Special emphasis must be given to safety consideration during the selection and in particular when these areas also serve as sites for recreational equipment or apparatus aimed at total community use.
3. The teacher should be in the vicinity of the equipment when it is being used by students and they should give their total attention to the supervision of the students.
4. Every school division should have a written policy for the ongoing inspection of all playground equipment and areas for hazards. A written record should be maintained that would certify that the inspection has been done.
5. A written plan for the repair or replacement of equipment should be available.

Appendix J

**Letter Establishing Meeting
with Liz Campbell,
Supervisor of Programs,
Department of Social
Services, Division of
Licensing Programs**

May 18, 1991

Ms. Liz Campbell
Department of Social Services
Division of Licensing Programs
8007 Discovery Drive
Richmond, VA 23229

Dear Liz:

Thank you so much for agreeing to share your expertise regarding playground safety with us. As you know, the Department of Education is completing a study of playground safety in the public schools. This study is in response to HJR 473. I have enclosed a copy of HJR 473 and a draft copy of our implementation plan. We welcome your feedback--are we missing any important sources of information?

We look forward to your discussion of the proposed Child Care Licensing Requirements and of information from the Consumer Product Safety Commission. We will meet at the Department of Education (James Monroe Building) in the 20th floor conference room on May 28, 1991 at 2:00. There will be a VCR available for the CPS videotape.

In addition to me, our team is composed of Valerie Barrett, Associate Specialist, Gifted Education (team leader); Chuck Hamm, Associate Specialist, Health and Physical Education; Jim Firebaugh, Principal Specialist, Science; Vijay Ramnarain, Architectural Consultant; and Elaine Granger, Associate Specialist, Educational Measurement. If you wish to share handouts with us prior to the meeting, it will be easiest for you to direct them all to me (VA DOE, Division of Early Childhood, P.O. Box 6-Q, Richmond, VA 23216.) I will distribute them to the others.

Again, we appreciate your willingness to assist with this study. It is imperative that our departments work together to improve the safety of all playgrounds within the Commonwealth.

Sincerely,

Jaye Harvey, Ed.D.
Associate Specialist
Early Childhood Special Education

C. Valerie Barrett

Appendix K

Sample Survey Responses from State Education Agencies

JUL 08 1991

COMMONWEALTH OF VIRGINIA
DEPARTMENT OF EDUCATION
INFORMATION REQUEST
STATE GUIDELINES FOR SCHOOL PLAYGROUND EQUIPMENT

State Louisiana Department of Education
Person Responding/Title Mari Ann Fowler
Phone Number (504) 342-3404

Check the appropriate space(s):

My state does not have guidelines concerning school playground equipment.

My state does have guidelines concerning school playground equipment.

My state's guidelines are mandated by legislature.

A copy of my state's guidelines concerning school playground equipment is enclosed.
(See attachment)

Comments Louisiana guidelines require that schools and school systems
have physical facilities which conform to federal, state, and local
building fire, safety and health codes. Systems (accreditation) and
schools (approval) classification reflect compliance.

Return by August 1, 1991 to:

Mrs. Valerie Barrett
Commonwealth of Virginia
Department of Education
Early Childhood Student Services Division - 20th Floor
P. O. Box 6-Q
Richmond, Virginia 23216-2060

SYSTEM POLICIES AND STANDARDS**SCHOOL POLICIES AND STANDARDS****OPERATION AND ADMINISTRATION****GENERAL AUTHORITY**

- 1.001.00 The public school system established under the Constitution shall operate in accordance with the standards set by the State Board of Elementary and Secondary Education (SBESE). The State Board of Elementary and Secondary Education (SBESE) has established measurable standards of operation for the approval of schools, stating the responsibility of the local educational governing authority.
- 1.001.01 Any deviations in the implementation of a policy or standard shall be authorized by the State Board of Elementary and Secondary Education (SBESE).

School systems which fail to comply with policies of the State Board of Elementary and Secondary Education (SBESE) shall be accountable as provided in R.S. 17:10E.

SYSTEM ADMINISTRATION

- 1.002.00 The organization and administration of education in the school system shall be that which best meets the needs of the students, the community, and the society, and fulfill the purpose for which the school system was organized.

PHILOSOPHY AND PURPOSES

- 1.003.00 It shall be the responsibility of each school system to formulate a written statement of its philosophy and purposes.

This statement shall give direction to the educational program. The philosophy and purposes shall be on a system-wide basis and shall be adapted to meet the needs of each school within the system.

- 1.003.01 It shall be the responsibility of the local educational governing authority and the superintendent in the school system to adopt an official statement of philosophy and purposes.
- 1.003.02 The statement of philosophy and purposes shall be reviewed annually and shall be revised as necessary. Written evidence that these requirements are being met shall be on file.

SCHOOL ADMINISTRATION

- 2.002.00 The organization and administration of education in the school shall be that which best meets the needs of the students, the community, and the society, and fulfill the purpose for which the school was organized.

PHILOSOPHY AND PURPOSES OF SCHOOL

- 2.003.00 It shall be the responsibility of each school to formulate a written statement of its philosophy and purposes.

This statement shall give direction to the educational program. The philosophy and purposes shall be on a system-wide basis and shall be adapted to meet the needs of each school within the system.

- 2.003.01 Each school shall adopt a philosophy and objectives to coordinate with those of the local educational governing authority.
- 2.003.02 The statement of philosophy and purposes shall be reviewed annually and shall be revised as necessary. Written evidence that these requirements are being met shall be on file.

SYSTEM POLICIES AND STANDARDS

- 1.003.03 Copies of the statement of philosophy and purposes shall be on file at the offices of the superintendent and the principal.
- 1.003.04 Copies of the statement of philosophy and purposes shall be furnished to all staff members and shall be made available to interested persons upon request.
- 1.003.05 The educational program shall be designed to implement the stated philosophy and purposes.

SYSTEM ACCREDITATION

- 1.004.00 Each school system shall participate in a program of system accreditation and receive a classification granted by the State Department of Education based upon a fifth-year on-site verification of the Annual System and School Reports.
- 1.004.01 All school systems shall receive an accreditation classification.

Classification Categories

School systems shall be classified according to the following categories based upon the fifth year on-site visitation:

ACCREDITED

The programs offered by the school system are in compliance with the policies and standards of the State Board of Elementary and Secondary Education (SBESE).

ACCREDITED PROVISIONALLY

One or more programs offered by the school system has deficiencies in standards other than those stated in the probational category, and the system is being advised and requested to make corrections. Improvement is expected prior to the next school year.

ACCREDITED PROBABLY

One or more programs offered by the school has major deficiencies in one or more of the following areas:

- A. There are member(s) of the professional staff not holding valid Louisiana teaching certificate(s).
- B. The school system does not offer a curriculum to meet graduation requirements or a balanced elementary curriculum as prescribed in this bulletin.

SCHOOL POLICIES AND STANDARDS

- 2.003.03 Copies of the statement of philosophy and purposes shall be on file at the offices of the superintendent and the principal.
- 2.003.04 Copies of the statement of philosophy and purposes shall be furnished to all staff members and shall be made available to interested persons upon request.
- 2.003.05 The educational program shall be designed to implement the stated philosophy and purposes.

- C. The school system has a student who is currently enrolled in a special education program and whose last individual evaluation occurred three or more years ago.
- D. The school system has an identified exceptional student who does not have a current Individualized Education Program (IEP).
- E. The school system does not adhere to and implement the various sections of the Revised Statutes of Louisiana as they affect the health and safety of the students and staff. (These include fire prevention and drills, provisions for a healthful environment, and safety regulations for transportation.)
- F. The physical facilities do not conform to the current federal, state, and local building fire, safety, and health codes.
- G. If deficiencies are cited, after being accredited provisionally for one year, the system shall be accredited probationally.

UNACCREDITED

If deficiencies are cited, after being accredited probationally for one year, the system shall be unaccredited.

A school system's accreditation status may be altered (either upgraded or downgraded) based upon either the on-site verification of the implementation of the action plan and/or the on-site verification of the Annual School and System Report.

SPECIAL EDUCATION COMPLIANCE MONITORING

1.005.00 Each school system shall participate in a system of special education compliance monitoring.

The school system shall receive a formal compliance document that describes any corrective actions that must be taken and timelines for correction based on a third-year on-site administrative review.

SYSTEM POLICIES AND STANDARDS

SCHOOL POLICIES AND STANDARDS

SCHOOL APPROVAL

- 1.006.00 In order to benefit from State and Federal funds, each school within a school system shall have a State approval classification.

SCHOOL APPROVAL

- 2.006.00 Each elementary and secondary, vocational-technical, and special school under the jurisdiction of the State Board of Elementary and Secondary Education (SBESE) shall participate in a program of school approval and receive an approved classification category from the State Department of Education based upon information conforming with the analysis of the Annual School Report in order to benefit from State and Federal funds.

Refer to R.S. 17:10.

SYSTEM POLICIES AND STANDARDS

SCHOOL POLICIES AND STANDARDS

1.006.02 All schools within a school system shall apply to the State Department of Education (SDE) for a classification category.

Classification Categories

Schools shall be classified according to the following categories:

APPROVED

School meets standards of State Board of Elementary and Secondary Education (SBESE)

APPROVED PROVISIONALLY

School has some deficiencies in standards other than those stated in the probational category and is being advised and requested to make corrections. Improvement is expected prior to the next school year.

APPROVED PROBATIONALLY

School has one or more of the following deviations from standards:

- A. The principal is not certified.
- B. There are member(s) of the faculty not holding valid Louisiana teaching certificate(s).
- C. The school does not offer a curriculum to meet graduation requirements or a balanced elementary curriculum as prescribed in this bulletin.
- D. The school has a student who is currently enrolled in a special education program and whose last individual evaluation occurred three or more years ago.
- E. The school has an identified exceptional student who does not have a current Individualized Education Program (IEP).

2.006.02 All schools shall apply to the State Department of Education (SDE) for a classification category.

Classification Categories

Schools shall be classified according to the following categories:

APPROVED

School meets standards of State Board of Elementary and Secondary Education (SBESE)

APPROVED PROVISIONALLY

School has some deficiencies in standards other than those stated in the probational category and is being advised and requested to make corrections. Improvement is expected prior to the next school year.

APPROVED PROBATIONALLY

School has one or more of the following deviations from standards:

- A. The principal is not certified.
- B. There are member(s) of the faculty not holding valid Louisiana teaching certificate(s).
- C. The school does not offer a curriculum to meet graduation requirements or a balanced elementary curriculum as prescribed in this bulletin.
- D. The school has a student who is currently enrolled in a special education program and whose last individual evaluation occurred three or more years ago.
- E. The school has an identified exceptional student who does not have a current Individualized Education Program (IEP).

SYSTEM POLICIES AND STANDARDS

SCHOOL POLICIES AND STANDARDS

- F. The school does not adhere to and implement the various sections of the Revised Statutes of Louisiana as they affect the health and safety of the students and staff. (These include fire prevention and drills, provisions for a healthful environment, and safety regulations for transportation.)
- G. The physical facilities do not conform to the current Federal, State, and local building fire, safety, and health codes.
- H. The school has been on provisional approval for at least two years.

UNAPPROVED

Any school that has not corrected the stated deficiencies within the time fixed by the State Department of Education shall be unapproved.

The State Department of Education shall set the guidelines and fix the period of time for the corrections.

Initial Classification

I.006.03

A school shall be established by resolution of its local educational governing authority which shall justify the need for its establishment to the State Board of Elementary and Secondary Education (SBESE).

Before a school system shall use property for educational purposes, it must obtain approval of the State Board of Elementary and Secondary Education (SBESE) for educational adequacy. Moreover, approval of the Department of Environmental Quality (Act 97 of 1983) and other appropriate State agencies shall be required.

- F. The school does not adhere to and implement the various sections of the Revised Statutes of Louisiana as they affect the health and safety of the students and staff. (These include fire prevention and drills, provisions for a health environment, and safety regulations for transportation.)
- G. The physical facilities do not conform to the current Federal, State, and local building fire, safety, and health codes.
- H. The school has been on provisional approval for at least two years.

UNAPPROVED

Any school that has not corrected the stated deficiencies within the time fixed by the State Department of Education shall be unapproved.

The State Department of Education shall set the guidelines and fix the period of time for the corrections.

SYSTEM POLICIES AND STANDARDS

SCHOOL POLICIES AND STANDARDS

CLASSIFICATION OF ESTABLISHED SCHOOLS

- 1.006.06 The local superintendent shall require from the principal of each school, on or before the date established by the State Department of Education, the completed Annual School Report based upon minimum requirements for school approval.
- 1.006.07 The local superintendent shall submit to the State Superintendent of Education, on or before the date established by the State Department of Education, an Annual School Report for each school in the system showing the extent to which each school is meeting the minimum requirements for classification.

A composite report of the findings and ratings of the schools by the State Department of Education shall be presented to the State Superintendent of Education for final action and submission of a report to the State Board of Elementary and Secondary Education (SBESE).

CLASSIFICATION OF ESTABLISHED SCHOOLS

- 2.006.06 The local superintendent shall require from the principal of each school, on or before the date established by the State Department of Education, the completed Annual School Report based upon minimum requirements for school approval.

JUN. 28 1991

COMMONWEALTH OF VIRGINIA
DEPARTMENT OF EDUCATION
INFORMATION REQUEST
STATE GUIDELINES FOR SCHOOL PLAYGROUND EQUIPMENT

State Kansas
Person Responding/Title Gerald Christensen Community Ed. Spec.
Phone Number (913) 296-3141

Check the appropriate space(s):

My state does not have guidelines concerning school playground equipment.

My state does have guidelines concerning school playground equipment.

My state's guidelines are mandated by legislature.

A copy of my state's guidelines concerning school playground equipment is enclosed.

Comments _____

Return by August 1, 1991 to:

Mrs. Valerie Barrett
Commonwealth of Virginia
Department of Education
Early Childhood Student Services Division - 20th Floor
P. O. Box 6-Q
Richmond, Virginia 23216-2060

Appendix L

Analysis of the State Regulations for Elementary Schools - Focus on Playgrounds and Supervision

Appendix M

Handbooks for Public

Safety, Volumes I & II

Produced by U. S. Consumer
Product Safety Commission

A HANDBOOK FOR PUBLIC PLAYGROUND SAFETY

Volume I: General Guidelines for
New and Existing Playgrounds

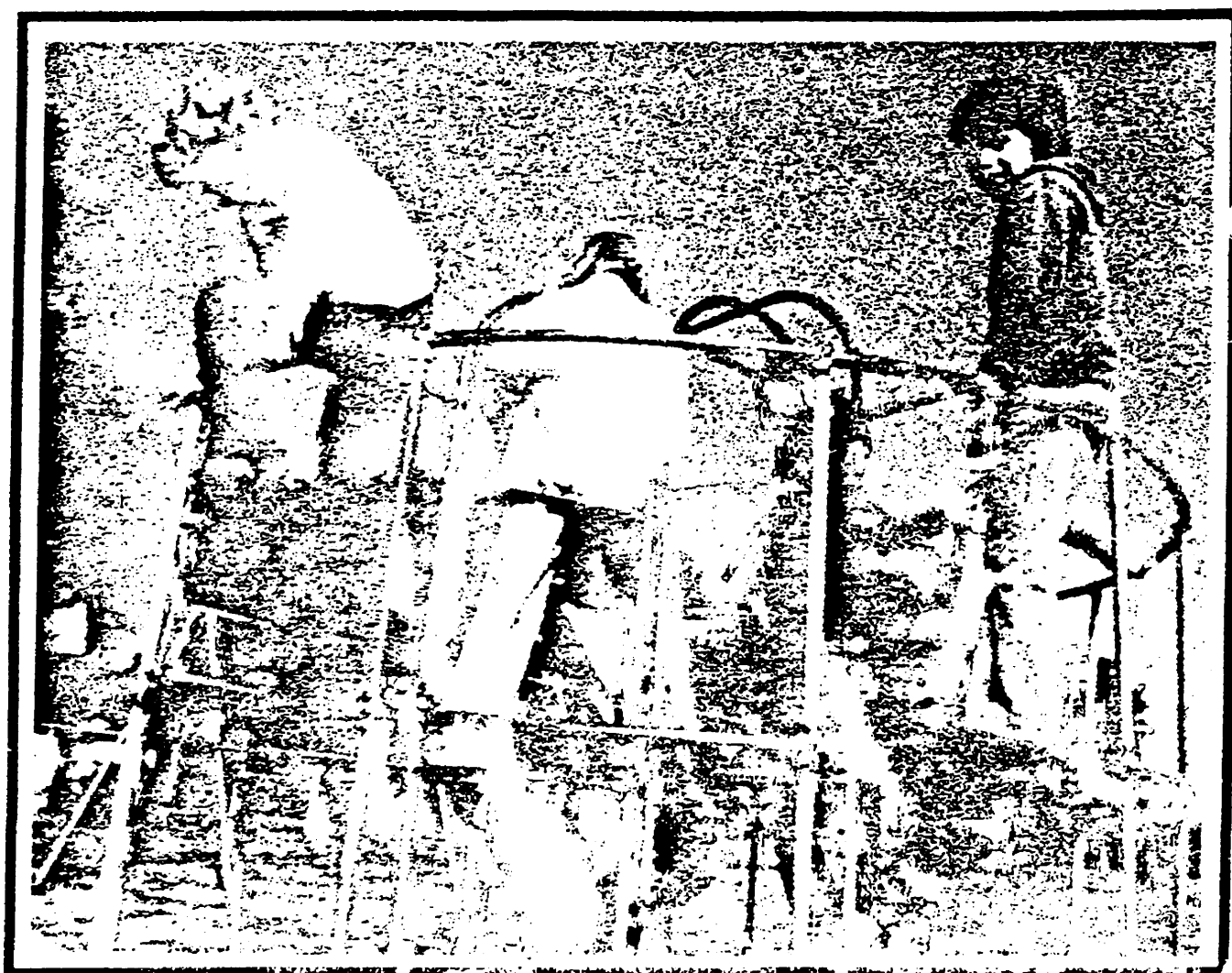

U.S. CONSUMER PRODUCT SAFETY COMMISSION, WASHINGTON, D.C. 20207

A HANDBOOK FOR
PUBLIC PLAYGROUND SAFETY

Volume I: General Guidelines for
New and Existing Playgrounds



U.S. CONSUMER PRODUCT SAFETY COMMISSION
WASHINGTON, D.C. 20207

CONTENTS

SECTION	PAGE
1. Introduction	1
2. Background	2
3. Playground Injuries	3
4. Planning a New Playground	4
Surfacing	4
Layout and Design	5
Equipment	6
5. Making Existing Playgrounds Safer	10
6. Summary	11
7. Playground Safety Checklists.....	12

1. Introduction

There are many kinds of public playgrounds in use today, and a wide variety of equipment available. Playgrounds with traditional slides, swings, and jungle gyms have been used and enjoyed for years. The most recent trends toward innovative play spaces—adventure or developmental playgrounds, for example—have inspired unique and unconventional equipment. Some communities have constructed playgrounds with components such as railroad ties and tires; others have chosen new equipment from manufacturers' catalogues.

While this handbook does not cover all the different types of equipment which exist, it does present some general guidelines that responsible officials and parents may use to increase the safety of public playgrounds for our children. The handbook is intended to provide information about hazards associated with the use of public playground equipment and suggestions for helping to reduce the frequency and severity of injuries.

Children use playground equipment in many diverse, yet predictable, ways. This booklet begins with a discussion of playground related injuries and the common accident patterns associated with children's play.

The next section, devoted to planning new playgrounds, suggests measures for designing playgrounds which take into account children's reasonably foreseeable use of equipment. In addition, we have included a section which suggests ways to make existing playgrounds safer. Because the life of equipment can range from 15-20 years, updating and maintaining playgrounds and equipment are essential for continued safety. The handbook concludes with a series of checklists which may be helpful in maintaining playground safety.

The Consumer Product Safety Commission (CPSC) has also developed a companion handbook that suggests technical guidelines and test procedures to help manufacturers and installers assure the structural integrity and safety of the equipment. Manufacturers, playground planners and designers, installers, and equipment purchasers, such as park and recreation and school system officials, may be interested in the more technical guidelines presented in companion Volume II: *Technical Guidelines for Equipment and Surfacing*. Copies of both volumes can be obtained by writing the Consumer Product Safety Commission, Washington, D.C. 20207.

2. Background

The CPSC has been studying public playground equipment for a number of years in an attempt to reduce playground injuries. In 1977 alone, for example, an estimated 93,000 injuries associated with public playground equipment were treated in hospital emergency rooms.

The Commission first became involved with playground safety in 1974, when a consumer petitioned CPSC to develop mandatory safety standards for public playground equipment. The National Recreation and Park Association (NRPA) was selected by the Commission to develop a draft standard. In 1976, when the NRPA draft standard was completed, the Commission contracted with the National Bureau of Standards for additional technical work needed to revise the NRPA recommended standard. Because surfaces under equipment appeared to play a major role in equipment injuries, the Commission also asked NBS to develop a method for testing various surfaces commonly used under playground equipment. The results of the NBS studies and research provide the basis for this two-volume handbook for public playground safety.

While the Commission's initial work was clearly oriented toward developing mandatory safety standards for equipment, the Commission decided not to issue such a mandatory standard. Over the years, its evaluation of playground safety led the Commission to conclude that a mandatory specification rule by itself would not adequately address the problem of playground injuries. Such factors as the diverse ways equipment is used, the varying quality of supervision on equipment, equipment placement, and equipment maintenance all play a part in playground injuries. In addition, most injuries associated with playground

~~equipment are caused by factors which would not be~~
addressed by equipment specifications alone.

The Commission believes, however, that the results of the studies and research conducted by the NRPA and NBS can serve as **guidelines** for the design of public playground equipment, and can be used by people involved with playground safety to help reduce the frequency and severity of injuries associated with equipment. Technical rationale is provided to explain each guideline. The guidelines are not a CPSC standard and are not mandatory requirements.

Since the guidelines are not a CPSC standard, the Commission is not endorsing them as the exclusive method of safe playground equipment construction. The Commission believes, however, that the safety features in many of the guidelines, such as those addressing protrusions, slip-resistant surfaces, durability and stability, and so forth, will contribute to greater equipment safety, and that publication of the guidelines as a whole will promote greater safety consciousness among manufacturers and purchasers of equipment.

The guidelines are recommended for playground equipment intended for use in play areas of parks, schools, institutions, multiple family dwellings, private resorts and recreation developments, and other areas of public institutional use. The guidelines are not intended to apply to amusement park equipment, equipment normally intended for sports' use or to home playground equipment. Components of equipment intended solely for use by the handicapped and necessarily modified to accommodate such users safely are also not covered by these guidelines.

3. Playground Injuries

The Commission became concerned about the safety of public playground equipment after examining the number and kinds of injuries associated with use of the equipment. A December 1978 CPSC *Hazard Analysis*, for example, estimates that in 1977 about 93,000 people were treated in hospital emergency rooms for injuries associated with public playground equipment. Children 10 years of age or younger suffered 4 out of 5 of the injuries. Some of these injuries were caused when children were struck by moving pieces of equipment such as swings and gliders. Other children were injured when they caught an extremity such as a finger at a pivot or pinch point, or ran or fell against protruding bolts, screws or other hardware on the equipment. Seven out of every ten injuries, however, were caused by falls—the most common playground accident.

The type of surface on the playground was a major factor affecting the number and severity of injuries associated with falls. Falls onto paved surfaces resulted in a disproportionately high number of severe injuries. While protective surfaces such as wood chips, shredded tires, sand, etc. may not have reduced the number of injuries from falls, these materials may have reduced the severity of the injuries.

The following table¹ presents the estimated percentage of public playground equipment related injuries according to the manner in which the injuries occurred:

Falls to surface	59%
Falls - struck same piece of equipment	11%
Falls - from one piece of equipment and struck another piece of equipment	2%
Falls-subtotal	72%
Impact with moving equipment	7%
Contact with protrusions, pinch points, sharp edges and sharp points	5%
Fell against, onto or into stationary equipment	8%
Unknown	8%
Total	100%

(1) Source: NEISS emergency room based special study April 10, 1978 - May 1, 1978, U.S. Consumer Product Safety Commission, Directorate for Hazard Identification and Analysis.

Hazards Relating to the Most Common Types of Public Playground Equipment

Traditional categories of playground equipment— swings, slides, seesaws, climbers, and merry-go-rounds— are used in many playgrounds throughout the country. The following table² compares the estimated percentage of injuries related to a particular type of equipment with the percentage of that equipment in use:

	INJURIES	EQUIPMENT IN USE
Climbers	42%	51%
Swings	23%	20%
Slides	16%	12%
Merry-go-rounds	8%	5%
Seesaws	5%	6%
All other	6%	6%
	100%	100%

Typical accident patterns associated with these conventional types of public playground equipment are described below.

Climbing Apparatus. Falls accounted for 72 percent of the injuries from climbing apparatus such as monkey bars, chinning bars, etc. Victims fell when they slipped, lost their grip or lost their balance. Falls occurred when children were swinging from rung to rung, performing stunts and jumping on, or from, bars.

Swings. Sixty-nine percent of the injuries related to swings occurred when children fell or jumped from the swings. Twenty-six percent of the injuries resulted when the children were struck by a moving swing.

Slides. Seventy-eight percent of the injuries on slides were the result of falls over the side, from the platform, and from the ladder. Falls were caused by roughhousing, walking up and down the slide, losing one's grip, slipping, and

(2) Source: NEISS emergency room based special study, April 10, 1978 - May 1, 1978 and Consumer Deputy Study of Playground Surfaces, September 13, 1978 - October 16, 1978, U.S. Consumer Product Safety Commission, Directorate for Hazard Identification and Analysis.

losing balance. Other victims hit protruding bolts, struck the slide rim and edge, or slipped on the ladder and struck the steps.

Merry-go-rounds. Most of the injuries associated with merry-go-rounds resulted from falls when children either lost their grip and were thrown from the merry-go-round, fell down while pushing it, or fell while riding it. In some instances those who were pushing were struck by the device. Those who fell while on the merry-go-round either struck or were struck by other gripping bars, or struck the base itself.

Seesaws. Although about one out of every six injuries occurred when the victim was hit by a moving seesaw, most injuries resulted from falls. In some cases, the victims were punctured by long splinters from worn, poorly maintained or damaged wooden seesaws.

Other. Other types of equipment involved in injuries were spring action riding equipment, rope or tire swings, etc. Typically, falls contributed to over half of the injuries associated with this equipment.

4. Planning a New Playground Surfacing

As indicated in the preceding chapter on playground injuries, falls are the most common type of playground accident. Commission studies show that the majority (from 60 to 70 percent) of playground-related injuries are caused when children fall from the equipment and strike the underlying surface. Nearly half the injuries that result from falls are to the head, and range in severity from minor bruises to skull fractures, concussions, brain damage, and even death.

Until recently, little information was available on the relative ability of surfacing materials to protect children from head injuries resulting from falls. Therefore, the Commission sponsored research by the National Bureau of Standards to develop a method for assessing the energy absorbing characteristics of playground surfaces and to test several commonly used surfaces.

Analyses of the test results indicate that, while they may require little maintenance or repair, **hard surfacing materials such as asphalt and concrete do not provide injury protection from accidental fall impacts and are therefore unsuitable for use under public playground equipment.** More resilient surfacing materials such as bark, wood chips, or shredded tires, for example, appear to provide greater protection to a child in the event of a fall. However, these materials require continuous maintenance to retain their optimum cushioning effectiveness.

The choice of surfacing material will, of course, be based in part upon local conditions and financial considerations. The following descriptions of some surfacing materials and the environmental conditions which affect them are offered to help planners in weighing the advantages and disadvantages of various surfaces.

Organic Loose Materials (Pine Bark Nuggets, Pine Bark Mulch, Shredded Hardwood Bark, Cocoa Shell Mulch). The cushioning potential of these materials depends upon the air trapped within and between the individual particles. Therefore, if materials decompose and become pulverized over a period of time, or mix with dirt, they will tend to lose their cushioning properties. Cushioning protection is also decreased in rainy or humid weather when the materials absorb moisture and tend to pack down, or if the temperature drops and the wet

materials freeze. Moisture can also promote the growth of various types of microorganisms which might allow transmission of communicable diseases.

Because strong winds can erode these materials, reducing the thickness required to protect against injury, and because the playing action of children can push the protective materials away from fall areas, frequent grading and leveling are necessary to maintain a suggested 6 inch depth. Careful maintenance is also necessary to eliminate insects, animal excrement and other trash or litter such as broken glass, nails, metal tabs from cans, pencils or other sharp objects which can be concealed by loose material. The cushioning protection that the materials provide against injuries from falls, however, makes the extra care worth the effort.

Inorganic Loose Materials (Sand, Pea Gravel, Shredded Tires, etc.). Like organic loose materials, these materials also require frequent leveling to replace material that is pushed or blown away from fall areas, and grading or sifting to remove foreign matter. Under conditions of constant use, the materials may combine with dirt or other matter, thus reducing their cushioning properties. Again, moisture tends to make the materials more cohesive, therefore less cushioning. When sand, for example, is thoroughly wet, it loses its resiliency. In wet, freezing conditions, some materials solidify into hard, packed ice. Other types, such as pea gravel, may be difficult to run or walk on. Inorganic, like organic loose fill materials, may be blown or thrown into children's eyes. Some types of rock can also release dust which can irritate the skin or nose and mouth.

Compact Materials (Outdoor Rubber Mats, Indoor Gym Mats, Synthetic Turf, etc.). While the cushioning properties of these materials will depend upon the foundation or surface over which the material is installed, unitary or whole materials such as rubber mats generally do provide protection from falls from 5 feet or less. The materials should always be used on essentially level, uniform surfaces. Compact materials require little maintenance; however, they may be attractive targets for defacing, ignition, or other vandalism.

Soil. In general, soils appear to offer more protection from injuries than do asphalt or concrete, but less than do loose surfacing materials. Grass may provide additional cushioning, but is difficult to maintain in areas of heavy

use. Soil will be influenced by many of the environmental factors described above.

Concrete, Asphalt and Paved Surfaces. Although paved surfaces require little or no maintenance, they are major contributors to playground injuries. **Concrete, asphalt and similar materials are not recommended for use under playground equipment because of their hard, unyielding characteristics.**

Layout and Design

To encourage a child's perceptual and motor development, a well-planned playground should offer a wide variety of play opportunities. Activities which involve running, walking, climbing, dodging, swinging, sliding, catching and throwing, or pulling and pushing, for example, help children learn to move confidently, gain muscle strength and control, and refine their coordination. Of course, many playgrounds are used by different age groups whose interests and abilities vary greatly. To allow the space appropriate to both the child and the activity, therefore, some planners set aside sections of the playground for special use.

For example, playgrounds might include:

- an open field for ball games, tag, kite-flying, etc. where children will have the freedom to run without jeopardizing the safety of others playing nearby;
- an area for pre-school children, equipped with appropriately sized swings, low slides, sand boxes, etc.;
- an apparatus area for conventional playground equipment;
- a free play area for activities such as tether tennis or hopscotch;
- a paved, multiple use area for court games, dancing, general play;
- an area for quiet activities or individual play such as arts and crafts, music, drama, solitary games; and
- other options such as wading pools, shelter houses, and landscaped areas.

Apart from the creative play opportunities which these special use areas can provide, the separation of play spaces will contribute to playground safety. Young children can be protected from the more active play of older children. Thought may also be given to separate

but adjoining play areas for handicapped children. Because of their disabilities, handicapped children may respond more slowly, either physically or mentally, to hazardous situations. Some newer playgrounds have been designed to provide activities which all children can share, and equipment which all can use safely and creatively.

No matter how play areas are organized, however, it is essential to provide adequate space around each piece of playground equipment. Planning should take into account the equipment's "use zone," that is, any activity or movement which can be expected around the equipment. For example, sufficient space should be allotted for swing sets to accommodate the largest arc through which the swing travels, including a child's extended legs. Adequate room must also be provided for children to exit slides, jump from swings, and "spin-off" from merry-go-rounds. Buildings, paths and walkways, gates, fences, and other play areas such as sand boxes should be located at least 8 feet away from the estimated use zone associated with a piece of playground equipment.

Equipment should also be arranged to accommodate the traffic of children at play. For example, playground apparatus should be placed away from ball fields or other areas where running children, intent upon their games, may accidentally move in front of swings, exit areas of slides, etc. Also, equipment should be placed so that one area is not overcrowded while another area remains underused. Poorly placed equipment can lead to misuse and accidents.

Generally, mapping out playground space before purchasing or installing permanent pieces of play equipment can encourage varied and safe activity. As areas are mapped out, planners should consider the traffic patterns which will result. Ample pathways should link activity areas, provide easy access from one piece of equipment to another and offer unobstructed vision from a child's height. Smoothly flowing traffic will eliminate many accidents such as collisions between children and equipment and between children and other children.

Planners should try to keep the site free from major visual barriers which would hamper supervision of the entire space. A fence or a relatively impenetrable border such as shrubbery or trees should enclose the entire site to keep children within the grounds and

prevent them from wandering into the street. The playground should be designed to permit maximum drainage so it can dry out as quickly as possible.

Whenever space and resources permit, consideration should be given to providing restroom facilities and pay telephones with permanently posted emergency numbers. Benches or other seating are usually appreciated by both children and adults.

Equipment

While manufacturers of public playground equipment conduct extensive tests of design and structural integrity, purchasers of equipment can help further playground safety by carefully reading and following information supplied with the equipment. Instructions for properly assembling equipment, including drawings, photos and other illustrations provided with each piece of playground equipment, should be followed carefully. To assure that equipment is properly installed, all directions, such as specifications for tightening nuts and bolts, must be adhered to.

Equipment selected should be constructed of materials which have proved durable in a playground or other outdoor setting. Metals should be painted or galvanized to prevent rust, and wood surfaces treated to prevent wood rot. No substances should be used in the material or treatment processes that, if released from equipment, could injure children if ingested, inhaled, or absorbed through the skin.

Purchasers should heed the manufacturers' recommendations for equipment spacing, as well as any warnings which caution against installing playground equipment over hard or unyielding surfaces. Many promotional materials and installation instructions will warn against placing equipment over paved surfaces such as concrete and asphalt because falls to these surfaces result in more severe injuries than do falls to more resilient surfaces.

Manufacturers should also provide instructions for anchoring equipment securely to the ground and directions for maintenance and general upkeep. Whenever possible, a permanent, durable label should appear on each unit identifying the manufacturer, unit model, month and year of manufacture. This data will allow purchasers to reach the manufacturer for additional information or to order parts for repairs.

The following guidelines for equipment safety were suggested by studies conducted by the National Bureau of Standards for the CPSC. These guidelines are not mandatory requirements for the design and construction of public playground equipment, and the Commission is not endorsing particular specifications in the guidelines. However, the Commission believes that publishing guidelines in this fashion will promote safer equipment.

General Hazards

Entrapment. No component or group of components should form angles or openings that could trap any part of a child's body or a child's head. If part of an accessible opening is too small to allow children to withdraw their heads easily and the children are unable to support their weight by means other than their heads or necks, strangulation may result. Swinging exercise rings (See Figure 1) with diameters of 5 to 10 inches, for example, could present such an entrapment hazard and should be removed.

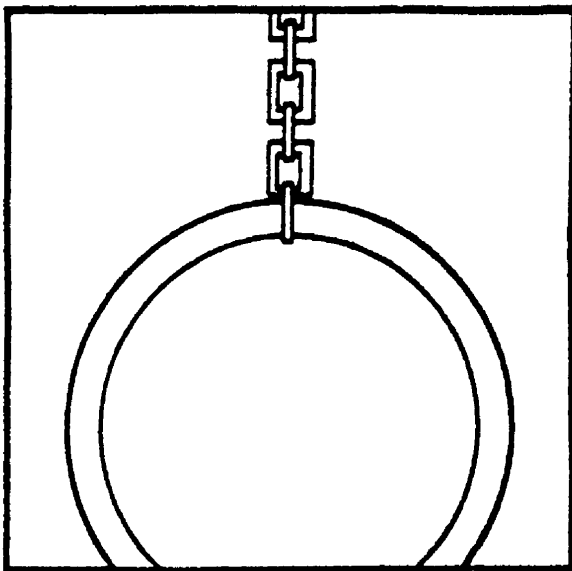

FIGURE 1

Similarly, children might become caught while trying to climb between narrowly spaced horizontal bars. If the distance between the bars is less than the height of a child's head, children will have difficulty rotating their heads backward to free them.

Clothing Entanglement. In general, accessible parts of moving apparatus and components next to sliding surfaces—ladders and uprights, protective barriers, handrails, etc.—should be designed so they cannot catch a child's clothing. If clothing is entangled, the

equipment's or child's momentum is often great enough to cause loss of balance or an injury.

Sharp points, corners, and edges; pinch and crush points; protrusions and projections. Playground equipment should present no accessible sharp edges or protruding points or ends that could cut or puncture children's skin or catch their clothing (See Figures 2 and 3).

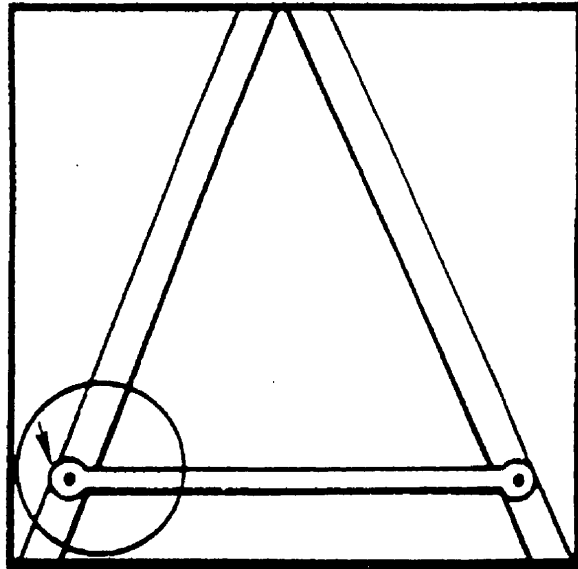

FIGURE 2

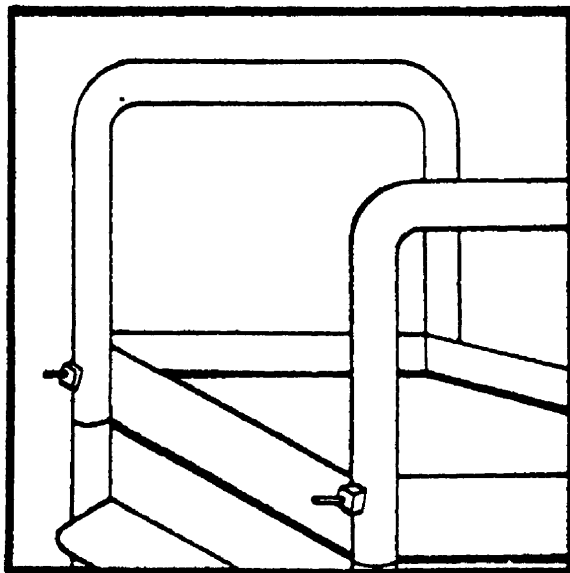

FIGURE 3

Manufacturers usually provide self-locking nuts or other devices to prevent nut and bolt assemblies from coming apart; these fasteners and exposed ends of bolts should be covered with smoothly finished protective caps which,

when correctly installed, are not removable by hand. Similarly, exposed ends of tubing which can lacerate or puncture a child's skin on impact should be covered with caps or plugs. Open ended "S" hooks (See Figure 4) that can catch clothing should also be avoided. If there are such open hooks, pinch the ends tightly closed.

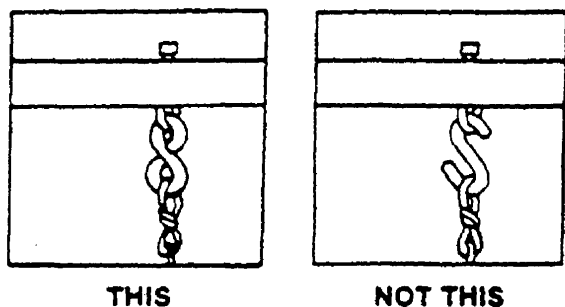

FIGURE 4

Whenever possible, avoid equipment with accessible pinch, crush, or scissor-like areas caused by adjacent moving components. Unprotected moving parts on gliders, merry-go-rounds, or seesaws, for example, could crush or pinch a child's fingers.

Guidelines for Specific Equipment

Climbing Equipment. Jungle gyms, monkey bars, geometric domes, and horizontal and arch ladders are popular types of climbing equipment. Other pieces may be designed to represent animals, ships, trains, etc. Regardless of configuration, the spacing of support members and climbing bars should be closely examined to ensure that it is neither too wide nor too tall to match children's arm or leg reaching abilities. Rungs of horizontal ladders, climbing bars, handrails, and other components intended to be gripped by the hands should be designed to be easily grasped by a child's hands. Preferably the components should be cylindrical and approximately 1½ inches in diameter, a size which average five-year-old children can grip comfortably and securely.

Climbing equipment should not lure a child to make an easy climb to the top without providing a way for the child to descend as easily, or furnishing a way out to another platform or piece of equipment for descent. A simple arch ladder, for example, may not offer an easy "way out" option. A child who begins this activity is forced to complete it, especially if others are waiting a turn to use the equipment.

Using bright, ~~as appropriate~~ colors on rungs or steps of climbing equipment can help children to perceive distances more accurately, thus improving their spatial judgment. Highly textured, slip resistant materials may enhance a child's gripping ability while at the same time increasing the amount of sensory feedback received while climbing.

Swings. Frequently swings stand as separate units on a playground. There may be from two to six or more swings in a series. A minimum clearance of 18 inches is recommended between the outside edges of swings and between the swings and nearby components such as frames or supporting structures. Clearance may need to be greater for tire swings or other swings that move in more than the traditional forward-backward direction. If the clearance is insufficient, swings may accidentally bump one another or other pieces of equipment. On the other hand, too wide a clearance might encourage a hazardous flow of traffic. Swings on swing sets should be located away from other activities or equipment to help prevent children from running into moving swings while chasing balls or when distracted by other activities.

A free swinging, empty swing seat can cause serious injury if it hits a child's head. Such an impact can result when children wander into the path of a swinging seat. To reduce the risk of serious injury, seats should be constructed of lightweight material such as plastic, canvas, or rubber. To help prevent cuts or scrapes, all seats should have smoothly finished or rounded edges. Tire swings are popular because they permit multiple occupancy and may provide less potential for harmful impact. Support frames for all swing sets should be designed to discourage climbing.

Slides. Sliding boards range from 4 to 16 feet in height and may be straight, spiral, wave or tubular (totally enclosed). Some short slides are wide enough to permit children to slide side by side.

To reduce the possibility of excessive speed, the average incline of the sliding surface should not exceed 30 degrees. Most slides available today have slide beds that are twice as long as they are high, with a resulting average incline of about 26 degrees. This design provides for a reasonably safe sliding speed.

Slides over 4 feet high should be equipped with sides at least 2½ inches in height for the

entire length of the sliding surface. These barriers also serve as hand and foot guides to help prevent falls off the edges of the slide.

Protective barriers for the area at the top of the slide help prevent falls while the child is changing from a climbing to a sliding position. As a safety precaution, slides over 4 feet high should have barriers at least 38 inches high. Solid barriers, or barriers with vertical rather than horizontal cross pieces, may discourage climbing. A horizontal platform at least 10 inches in length and as wide as the sliding surface at its entrance will help children easily make the transition from climbing to sliding.

Exit surfaces at the bottom of slides over 4 feet high should be at least 16 inches long and essentially parallel to the ground. To help children regain their upright posture and balance when their feet touch ground, the height of the exit should be between 9 and 15 inches above the ground. All slide exits should be located in uncongested areas out of the way of other play traffic.

Steps and rungs on slides and other equipment should be evenly spaced with at least 7 and not more than 11 inches between them to accommodate the arm and leg reaches of children. Steps and rungs should be at least 15 inches wide and horizontal to within plus or minus 2 degrees and corrugated, grooved or covered with a permanent slip resistant finish that is effective under both wet and dry conditions.

Stairways and ladders with steps should have continuous handrails on both sides. The handrails should be placed at a height which will allow the child to stand erect over each step.

To prevent unnatural or unusual climbing angles, ladders with rungs should have a slope between 75 and 90 degrees when measured from the horizontal. Ladders with steps should have a slope between 50 and 75 degrees and stairways should have a slope no greater than 35 degrees (See Figure 5).

Because metal slides left in the sun can cause burns, they should be placed in shaded areas or installed so that the sliding surface faces north whenever possible. Placing metal slides in a shaded location will also prevent them from reflecting the glare of the sun and interfering with children's vision.

Merry-Go-Rounds. The rotating portions of merry-go-rounds (the platform or base on which children stand or sit) should have an approximately circular shape. Handrails attached to the base to help prevent falls from the equipment should not protrude beyond the edge of the base. Such a design will reduce the risk of injury resulting from children walking into the path of the moving equipment. To ensure that no part of a child's body could pass through an opening and contact a stationary object beneath the apparatus, the rotating base of the equipment should have no spaces or openings that would permit penetration by a rod 3/10 of an inch in diameter.

FIGURE 5
(SIDE VIEW)

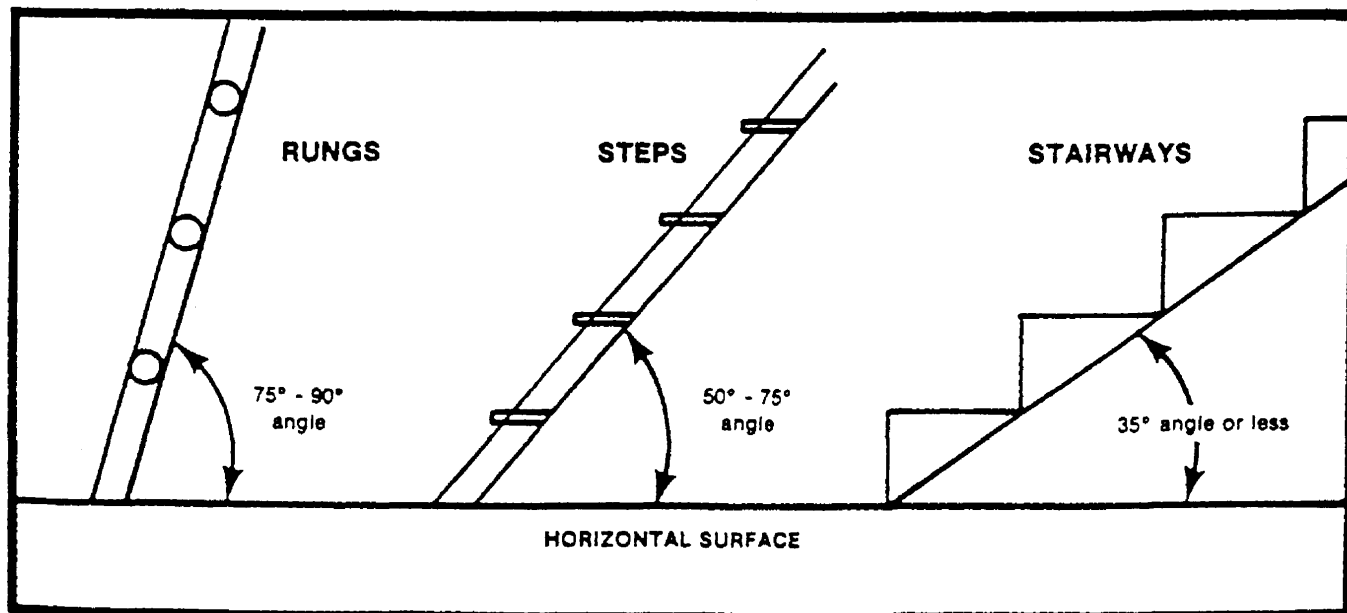

5. Making Existing Playgrounds

Safer

Public playground equipment can generally be expected to last from 10 to 15 years. Although manufacturers continue to redesign equipment to make it more enjoyable and safer, many years may pass before new equipment reaches the nation's playgrounds and makes a substantial impact on playground injuries.

Thus retrofitting and maintaining existing playgrounds and equipment play a vital role in improving playground safety. While some of the following suggestions for retrofitting or modifying playgrounds have been discussed earlier in this handbook, they are worth repeating here:

- **Remove equipment from asphalt or concrete surfaces.** Vacated areas can then be used for other activities such as hopscotch or basketball. If removing equipment is not feasible, cover the areas under equipment with heavy duty mats, etc., or add shock absorbent surfacing material in trouble areas, especially around high slides or areas where falls frequently occur.
- If equipment is crowded together causing an uneven distribution of children, consider moving some pieces out of the densely populated area to ease traffic.
- Do not hesitate to eliminate a piece of equipment which has been associated with frequent injuries. Take special note of slides more than 10 to 12 feet high; they present the potential for serious injury in the event of a fall.
- Equipment should be firmly anchored in the ground by concrete. Place concrete footings below ground level (See Figure 6) to prevent tripping and to protect a child in case of a fall.
- If any exposed concrete footings do exist, cover them with earth or padding. Also consider recovering worn surfaces where rocks or other hazards may protrude.
- Consider installing fences or other barriers between areas for active play, such as ball fields, and the immediate playground area where equipment is installed. Areas for running games may be separated from areas for passive play, picnicking, etc. Playgrounds should always be separated from roadways by a fence, wall, or other barrier.
- Barriers may also be installed between traditional apparatus and discovery or adventure playgrounds where children may be using tools and similar equipment.
- Remove one or two swings to reduce overcrowding of swingsets.
- Replace heavy swing seats with lightweight seats, e.g. canvas or plastic. Add tire swings, because they permit safe use by several children at one time, and their safety record appears to be better than that of conventional swings. Drill holes in tire swings to assure water drainage.
- Remove single cables, wires, ropes, or similar obstructions between play units which a child might accidentally run into or trip over. (This recommendation is not intended to eliminate items such as guard railings or series of ropes and cables such as cargo nets and climbing grids.)
- Install, or paint on, slip resistant surfaces on climbing and gripping components.
- Consider color coding equipment for different age groups and posting explanatory signs in prominent locations. Bright colored paint or tape can also make a potentially hazardous protrusion on a piece of equipment more visible.
- When a playground leader is not present, consider restricting children aged 1 to 5 from playground equipment unless they are accompanied by an adult.
- Provide clearly marked pathways and en-

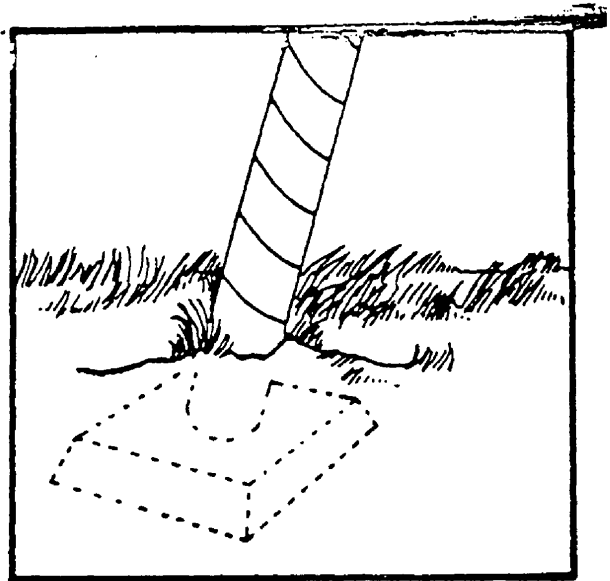

FIGURE 6

courage children to keep to the paths rather than cutting through areas where swings, merry-go-rounds, etc. are in motion.

- Homemade or community built equipment made of logs, railroad ties or landscape timber should receive special inspection and maintenance for splinters, rough edges, sharp corners, and loose or protruding nails, nuts, bolts, etc. Because cedar, redwood, and pressure treated lumber tend to resist deterioration, these materials are recommended in areas where the wood comes in contact with soil or in humid climates.
- Knowledge of first aid and accident prevention is very useful. In order to get help fast when needed, post emergency numbers in a prominent location—near a telephone, if one is available.
- Clean playgrounds regularly, being alert for hazards such as broken glass or sharp metal objects. Whenever possible, provide trash receptacles and empty them frequently.
- A regular inspection and maintenance schedule is essential to ensure the safety of the equipment and surrounding area. (See checklist on page 12 for suggestions.)

6. Summary

This handbook has provided some general guidelines for playground equipment and suggestions for the design, layout, surfacing and operation of public playgrounds which can help to make children's play safer.

Because children will use playground equipment in ways for which the equipment is not intended, however, even after design and mechanical hazards have been addressed and information and education programs undertaken, public playground equipment may still be associated with some accidents and injuries.

Thus, close supervision of children as they play and intensive classroom and home instruction about safe behavior on playground equipment make an important contribution to playground safety. Through the attention and care of parents, schools, and community organizations, the number and severity of playground injuries can be further reduced.

7. Playground Safety Checklists

Suggested Public Playground Maintenance Checklist

Inspections should be conducted on a frequent, regularly scheduled basis. Following are some of the danger points that should be checked on each tour:

- Visible cracks, bending, warping, rusting, or breakage of any component.
- Deformation of open hooks, shackles, rings, links, etc.
- Worn swing hangers and chains.
- Missing, damaged, or loose swing seats; heavy seats with sharp edges or corners.
- Broken supports/anchors.
- Footings exposed, cracked, loose in ground.
- Accessible sharp edges or points.
- Exposed ends of tubing that should be covered by plugs or caps.
- Protruding bolt ends that do not have smooth finished caps and covers.
- Loose bolts, nuts, etc.
- Splintered, cracked or otherwise deteriorated wood.
- Lack of lubrication on moving parts.
- Worn bearings.
- Broken or missing rails, steps, rungs, seats.
- Surfacing material worn or scattered (in landing pits, etc.).
- Hard surfaces, especially under swings, slides, etc.
- Chipped or peeling paint.
- Vandalism (broken glass, trash, etc.).
- Pinch or crush points (exposed mechanisms, junctures of moving components, e.g., axis of seesaw).
- Tripping hazards such as roots, rocks or other environmental obstacles.
- Poor drainage areas.

Suggested Public Playground Leader's Checklist

- Prepare written guidelines for playground operation, defining goals and procedures.
- Insist on first aid and accident training for playground leaders.
- Provide for constant supervision by establishing a written schedule.
- Instruct children and playground supervisors on how to use equipment. (Playground equipment safety should be taught in the classroom.)
- Conduct daily cleaning and check for broken glass and other litter.
- Do not permit children to use wet or damaged equipment.
- Do not permit too many children on the same piece of equipment at the same time; suggest that children take turns, or direct their attention toward other equipment or activities.
- Constantly observe play patterns to note possible hazards and suggest appropriate equipment or usage changes.
- Make periodic checkups, and request that worn or damaged pieces of equipment be replaced.
- Prepare written accident reports with special attention to surface conditions, type and extent of injury, age and sex of child, how the accident occurred, and weather conditions.

Suggested Public Playground Planners' and Installers' Checklist

- Separation of equipment for different age groups.
- Placement of swing(s) or swing sets away from other activities or equipment.
- Adequate space for children to exit equipment such as slides or merry-go-rounds.
- Layout designed to promote a safe flow of traffic between areas.
- Fencing or other barriers to separate the playground from adjacent streets.
- Clearly marked "danger" zones (e.g., those areas covered by swinging seats from swing sets and areas in front of sliding boards).
- No equipment installed over hard surfaces such as concrete or asphalt.
- Accessible components of equipment adjacent to sliding surfaces shaped so that a child's clothing cannot be caught as the child uses the slides.
- No component or group of components forming angles or openings that could trap a child's head or any part of a child's body.
- Protective barriers on surfaces which are elevated more than 30 inches from an underlying surface, assuring that the barriers do not create another hazard (i.e., horizontal cross pieces on which children can climb).
- Handgripping components of size and shape to make them easy for a child to grasp.
- Climbing and gripping surfaces which are slip resistant under both wet and dry conditions.
- Explanation signs where needed, e.g., in color coded areas.

A HANDBOOK FOR PUBLIC PLAYGROUND SAFETY

Volume II: Technical Guidelines for
Equipment and Surfacing

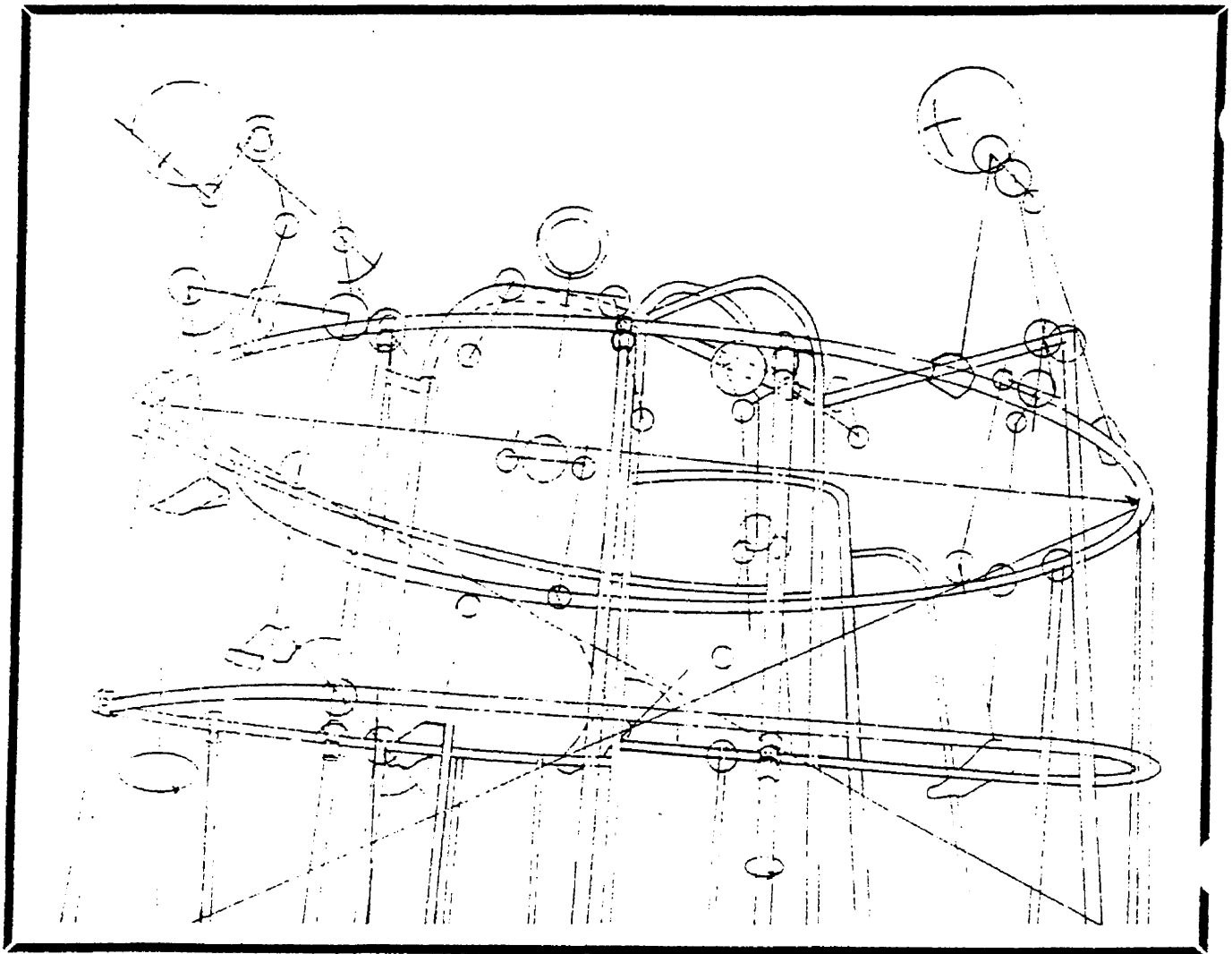

U.S. CONSUMER PRODUCT SAFETY COMMISSION, WASHINGTON, D.C. 20207

CONTENTS

SECTION	PAGE
1. Introduction	1
2. Background	1
3. Definitions	2
4. Assembly, Installation and Maintenance	3
4.1 Instructions	3
4.2 Identification	3
5. Materials of Manufacture and Construction	4
5.1 Durability	4
5.2 Finish	4
5.3 Stability	4
5.4 Hardware	4
6. Strength of Individual Components and Structures	4
6.1 Recommendations	4
6.2 Suggested Test Method	4
6.2.1 Swing Assemblies and Structures Supporting Swing Assemblies	5
6.2.1.1 Single Occupancy Swing Assemblies	5
6.2.1.2 Multiple Occupancy Swing Assemblies	5
6.2.1.3 Trapeze Bar	5
6.2.1.4 One Foot Support	5
6.2.1.5 Both Feet Support	5
6.2.1.6 Structures Supporting Swing Assemblies	5
6.2.1.7 Minimum Clearance of Suspended Members	6
6.2.2 Components and Structures Subjected to Vertical Loads	6
6.2.2.1 Individual Longitudinal Components	6
6.2.2.2 Structures Containing Two or More Longitudinal Components	6
6.2.2.3 Individual Surfaces	7
6.2.2.4 Structures Supporting Two or More Surfaces	7
6.2.2.5 Slide Beds	7
6.2.2.6 Other Structures	7
6.2.2.6.1 With Designated Occupancy	7
6.2.2.6.2 Without Designated Occupancy	7
6.2.3 Components Subjected to Lateral Loads	7
6.2.3.1 Concentrated Load	7
6.2.3.2 Distributed Load	7
7. Sharp Points, Corners and Edges; Pinch and Crush Points; Protrusions; Suspended Hazards	8
7.1 Sharp Points, Corners and Edges	8
7.2 Pinch and Crush Points	8
7.3 Protrusions	8
7.3.1 Recommendation	8
7.3.2 Suggested Test Method	9
7.3.3 Exclusions	9
7.3.3.1 Inaccessible Protrusions	9
7.3.3.2 Protrusions on the Front and Rear Surfaces of Suspended Members of Swing Assemblies ..	9
7.3.3.2.1 Recommendation	9
7.3.3.2.2 Suggested Test Method	9
7.4 Suspended Hazards	9
8. Base Configuration of Rotating Equipment	10
9. Moving Impact of Swings	10
9.1 Recommendation	10
9.2 Suggested Test Method	10
9.2.1 Ambient Laboratory Conditions	10
9.2.2 Test Equipment	10
9.2.2.1 Headform and Support Assembly	10
9.2.2.2 Guidance Structure	10

3.2.2.3	Instrumentation	12
9.2.3	Step 1. Index Mark	12
9.2.4	Step 2. Assembly and Installation	12
9.2.5	Step 3. Position of Suspended Member	12
9.2.6	Step 4. Placement of Suspended Member	12
9.2.6.1	Test Position 1	12
9.2.6.2	Test Position 2	13
9.2.6.3	Additional Instructions	13
9.2.7	Step 5. Support of Suspended Member	13
9.2.8	Step 6. Collection of Data	13
10.	Entrapment	13
10.1	General	13
10.2	Head Entrapment	13
10.2.1	Recommendations	13
10.2.1.1	Angles	13
10.2.1.2	Distance	13
10.2.1.3	Projected Lines of Intersection	14
10.2.2	Suggested Test Method	14
10.2.3	Exceptions to Paragraph 10.2.1	14
10.2.3.1	Exception 1	14
10.2.3.2	Exception 2	14
10.2.3.3	Exception 3	14
10.2.3.4	Exception 4	14
11.	Falls From Equipment	15
11.1	Elevated Surfaces	15
11.2	Hand Gripping Components	15
11.3	Ladders and Stairways	15
11.3.1	For Slope	15
11.3.1.1	Ladders with Rungs	15
11.3.1.2	Ladders with Steps	15
11.3.1.3	Stairways	15
11.3.2	For Steps and Rungs	15
11.3.2.1	Horizontality	15
11.3.2.2	Width	15
11.3.2.3	Spacing	15
11.3.2.4	Tread Depth	15
11.3.3	For Hand Rails	15
11.4	Slip-Resistant Surfaces	15
11.5	Straight Slides	15
11.5.1	For Side Height	15
11.5.2	For Slide Surface Slope	16
11.5.2.1	Average Incline	16
11.5.2.2	Span	16
11.5.3	For Exit Region: Slope, Length, Height, and Radius of Curvature	16
11.5.3.1	Slope	16
11.5.3.2	Length	16
11.5.3.3	Height	16
11.5.3.4	Radius	16
11.5.4	For Slide Surface Entrance	16
11.5.4.1	Platform	16
11.5.4.2	Protective Barrier	16
11.5.4.2.1	To Maintain Body Balance	17
11.5.4.2.2	Prevention of Falls	17
11.6	Spiral Slides	17
11.6.1	Lateral Discharge Mode by Tipping Over Outer Edge	17
11.6.2	Lateral Discharge Mode by Sliding Over Outer Edge	18
11.6.3	Lateral Discharge Mode Over Outer Edge, Not Obvious	19
11.6.4	Determination of Factors to Compute Outer Edge Discharge	19

11.5.4.1	Measurement of H	19
11.6.4.2	Measurement of R	19
11.6.4.3	Measurement of θ (Theta)	19
11.6.4.4	Measurement of ϕ (Phi)	19
11.6.5	Computation of Parameters for Outer Edge Discharge	19
11.6.5.1	Tipping	20
11.6.5.2	Sliding	20
11.6.6	Lateral Discharge Mode by Tipping or Sliding Over Inner Edge	22
11.6.7	Exit Region: Slope, Length, Height and Radius of Curvature	22
11.6.8	Slide Surface Entrance	22
12. Safety Guidelines for Surfaces Under Playground Equipment		22
12.1	Introductory Comments	22
12.2	Recommendation	22
12.3	Suggested Test Method and Equipment	22
12.4	Concrete, Asphalt and Similar Material	22
12.5	Influence of Environment on Surfaces	23
12.5.1	Loose Materials	23
12.5.1.1	Organic	23
12.5.1.2	Inorganic	23
12.5.2	Compact Materials	23
12.5.3	Soils	24
References		25

1. Introduction

This handbook suggests safety guidelines for public playground equipment and describes characteristics of various surfaces used under the equipment as the surfaces relate to injuries from falls. These safety guidelines are based on work performed for the Consumer Product Safety Commission (CPSC) by the National Bureau of Standards (NBS). This particular handbook is technical and is intended for use mainly by manufacturers, installers, school and park officials and others interested in technical criteria for public playground equipment. Manufacturers can use this information to design new equipment, and purchasers such as school and park officials can use it to help in the selection of appropriate equipment. The handbook may also be helpful in considering design and layout for improving playground safety.

Because the majority of public playground equipment injuries involve falls from the equipment, this handbook also presents information regarding the methodology for assessing impact attenuation of surfaces in relation to head injury. The handbook contains information on surfacing materials commonly available which might minimize head injury in fall situations.

A companion handbook has been prepared for general use by the public which summarizes these safety guidelines in less technical terms. The companion handbook also offers some general advice on the design, maintenance, retrofit and surfacing of public playgrounds.

2. Background

The CPSC has been studying public playground equipment for a number of years in an attempt to reduce playground injuries. In 1977 alone, for example, an estimated 93,000 injuries associated with public playground equipment were treated in hospital emergency rooms.

The Commission first became involved with playground safety in 1974, when a consumer petitioned CPSC to develop mandatory safety standards for public playground equipment. The National Recreation and Park Association (NRPA) was selected by the Commission to develop a draft standard. In 1976, when the NRPA draft standard was completed, the Commission contracted with the National Bureau of Standards for additional technical work needed to revise the NRPA recommended standard. Because surfaces under equipment appeared to play a major role in equipment

injuries, the Commission also asked NBS to develop a method for testing various surfaces commonly used under playground equipment. The results of the NBS studies and research provide the basis for this two-volume handbook for public playground safety.

While the Commission's initial work was clearly oriented toward developing mandatory safety standards for equipment, the Commission decided not to issue such a mandatory standard. Over the years, its evaluation of playground safety led the Commission to conclude that a mandatory specification rule by itself would not adequately address the problem of playground injuries. Such factors as the diverse ways equipment is used, the varying quality of supervision on equipment, equipment placement, and equipment maintenance all play a part in playground injuries. In addition, most injuries associated with playground equipment involved falls, which would not be addressed by equipment specifications alone.

The Commission believes, however, that the results of the studies and research conducted by the NRPA and NBS can serve as **guidelines** for the design of public playground equipment, and can be used by people involved with playground safety to help reduce the frequency and severity of injuries associated with equipment. Technical rationale is provided to explain each guideline. The guidelines are not a CPSC standard and are not mandatory requirements.

Since the guidelines are not a CPSC standard, the Commission is not endorsing them as the exclusive method of safe playground equipment construction. The Commission believes, however, that the safety features in many of the guidelines, such as those addressing protrusions, slip-resistant surfaces, durability and stability, and so forth, will contribute to greater equipment safety, and that publication of the guidelines as a whole will promote greater safety consciousness among manufacturers and purchasers of equipment.

The guidelines are recommended for playground equipment intended for use in play areas of parks, schools, institutions, multiple family dwellings, private resorts and recreation developments, and other areas of public institutional use. The guidelines are not intended to apply to amusement park equipment, equipment normally intended for sports' use or to home playground equipment. Components of equipment intended solely for use by the handicapped and necessarily modified to accommodate such users safely are also not covered by these guidelines.

3. Definitions

The following definitions apply for the purpose of these guidelines:

Accessible - Any part of the equipment that may be contacted by any body part under conditions of normal use.

Clearance height - The vertical distance between the underlying surface and the lowest part of the suspended member when the suspended member is in its rest position.

Composite unit - A combination of two or more play devices linked together to provide a variety of play activities in one integral unit (e.g., a combination climber, slide and balance beam).

Entrance height - The vertical distance between the underlying surface and the uppermost part of the inclined sliding surface of a slide.

Entrapment - Any condition which impedes withdrawal of a body or body part that has penetrated an opening.

Exit region - That part of the sliding surface at the exit end of a slide intended to aid the user in exiting safely.

Fasteners - Those parts of the equipment such as clamps, bolts, hooks, screws, or other hardware used to join components.

Hand railing - A device intended for use by the hands to provide body balance and support in maintaining a specific body posture.

Ladder - A device having a slope greater than 50 degrees from a horizontal plane, and consisting of a series of rungs or steps on which a person may step while ascending or descending.

Longitudinal component - A component (bar, rung, etc.) which provides an opportunity for climbing and is within 45 degrees from a horizontal plane.

Maximum user - A twelve year old child. Measurements of maximum user characteristics are the 95th percentile values for combined sexes. (See Reference 17).

Minimum user - A five year old child. Measurements of minimum user characteristics are the 5th percentile values for combined sexes. (See Reference 17).

Normal use - Use of the equipment in a manner intended by the designer or manufacturer or which conforms to play patterns that have been established by traditional practice.

Opening - A space bounded partially or completely by edges or surfaces of a structure.

Peak acceleration - The maximum acceleration imparted to a test headform during impact tests of suspended members or surfacing materials.

Pinch and crush point - The point at which the movement of elements relative to each other or to a fixed component represents a pinching, crushing, or shearing hazard to any body part.

Potential impact region - Any part of the front or rear surface of a suspended member which can contact an object in its intended path.

Protective barrier - A side enclosing device around an elevated surface that aids in the prevention of falls to lower levels.

Protrusion - An element or component that protrudes from the equipment in any plane or direction in a manner posing a potential impact hazard.

Reasonably foreseeable misuse - Use of the equipment in a manner not originally intended by the designer or manufacturer and not considered customary, but which may be anticipated through knowledge of children's behavioral patterns when using such equipment.

Rotating equipment - Any equipment which rotates about a vertical axis, such as merry-go-rounds, whirls, maypoles, etc.

Rung - A ladder crosspiece which is intended to be used as a foot support and as a hand grip in the normal use of the ladder.

Sharp edge - Any edge that can cut the skin during normal use.

Slide - An apparatus having an inclined surface used for sliding.

Spiral slide - A slide whose sliding surface (chute) when projected onto a horizontal plane is curved.

Stability - The ability of an apparatus to

withstand maximum anticipated forces which act to tip or slide the equipment when properly assembled and installed.

Stairway - A device having a slope of 50 degrees or less from a horizontal plane and consisting of a series of steps which can be used for ascending or descending.

Step - A horizontal crosspiece of a ladder or stairway intended for use primarily as a foot support.

Straight slide - A slide with a sliding surface which when projected onto a horizontal plane is not curved.

Suspended member - That part of a swing assembly which is intended to be occupied by one or more users in the act of swinging.

Suspending elements - Those parts of the swing assembly, such as chains, ropes, cables, tubes, etc., that are used to suspend a suspended member from an overhead supporting structure.

Swing - Play equipment used for swinging, consisting of the supporting structure and one or more swing assemblies.

Swing assembly - An apparatus intended for use by one or more users for swinging, consisting of a suspended member and its necessary suspending elements and fasteners.

Underlying surface - The top level of the natural ground or surfacing material placed under and around the equipment.

Use zone - The total space under and around installed equipment that is necessary for the user to complete the intended activity (e.g., swinging out, exiting from a slide, etc.).

4. Assembly, Installation and Maintenance

Instructions - The manufacturer should include the following with each piece of equipment or composite unit:

4.1

- Instructions and necessary drawings, photos, or other illustrations for proper assembly that include torque specifications for bolts and nuts and a listing of all components that includes part names and numbers where appropriate.
- Instructions and necessary drawings, photos, or other illustrations that provide essential information for installing the equipment or composite unit in accordance with the safety design intentions of the manufacturer. (For swing assemblies, these instructions should specify the manufacturer's recommended maximum length for suspending elements.)
- The manufacturer's recommended use zones for determining the placement of equipment.
- Instructions for the general maintenance of the equipment or composite unit.

NOTE: All promotional material and installation instructions should caution against installing playground equipment over paved surfaces such as concrete and asphalt because falls to these surfaces may result in more severe injuries than falls to more resilient surfaces.

Identification - A durable label should be permanently attached to each major unit (e.g. slide, climber, etc.) or composite unit identifying: manufacturer, model and month and year of manufacture. This label should be placed on the equipment in a prominent location.

4.2

5. Materials of Manufacture and Construction

- 5.1 Durability - Generally, equipment should be constructed using materials that have a demonstrated record of durability in the playground or a similar outdoor setting. New materials without a demonstrated record of durability may need to be tested in a manner considered appropriate by the manufacturer.
- 5.2 Finish - Materials subject to corrosion or deterioration should be plated, galvanized, painted, preserved, or otherwise treated to resist these effects. The manufacturer should ensure that users of the playground equipment cannot ingest, inhale, or absorb through body surfaces any hazardous substances used in the treatment process.
- 5.3 Stability - When properly installed as directed in the installation instructions or as specified on construction drawings, the equipment should withstand maximum anticipated forces generated by the users which might tend to tip or slide it.
- 5.4 Hardware - Lock washers, self-locking nuts, or other locking means should be provided for all nuts and bolts. Fasteners and connecting and covering devices, when torqued and installed in accordance with the manufacturer's instructions, should not loosen or be removable without the use of tools.

3. Strength of Individual Components and Structures

Recommendation - Manufacturers should test their playground equipment to determine if it is strong enough for its intended use.

6.1

The NBS has developed strength tests that can be used for playground equipment components and supporting structures. NBS recommends that playground equipment, when tested in accordance with those tests described in Paragraph 6.2, should withstand the specified loads. During and after the test there should be no visible crack or breakage of any component. There should be no other form of permanent deformation of any component that may adversely affect the structural integrity or safe use of the equipment. In the case of individual swing assemblies, hooks, shackles, rings and links should not open more than one-half of the cross sectional diameter of the component that they are intended to constrain.

Suggested Test Method - Make sure that the equipment is assembled and installed in accordance with the accompanying instructions, or supported in an equivalent manner. Test individual components and the supporting structure separately. Determine and apply the loads as specified in the following paragraphs. Apply the load gradually, attaining (but not exceeding) the specified value. Maintain the load for at least five minutes. Where specified, apply the load through appropriate load distribution devices of dimensions shown in Figure 1.

6.2

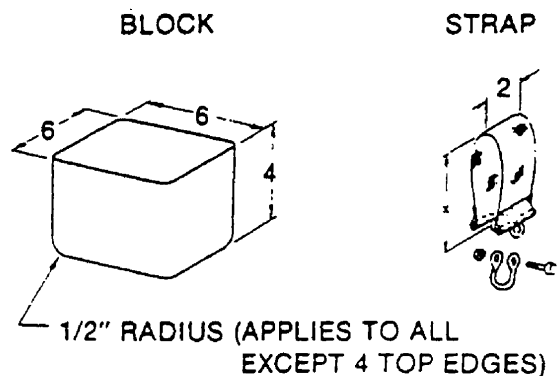

- NOTE: (1) BLOCK MADE OF ANY RIGID MATERIAL.
 (2) VARY DIMENSION "x" AS REQUIRED
 (3) ALL DIMENSIONS ARE IN INCHES.

FIGURE 1 - LOAD DISTRIBUTION DEVICES

NOTE: If a structural member supports a composite unit, load the unit simultaneously in accordance with the appropriate paragraph of Section 6. For swing assemblies with foot supports, load the seat and foot support separately.

- 6.2.1 Swing Assemblies and Structures Supporting Swing Assemblies.
 - 6.2.1.1 Single Occupancy Swing Assemblies - For swing assemblies intended for single occupancy, place a load distribution device on the center of the seat and apply a vertical downward force of 1200 pounds. Apply the force gradually until it attains but does not exceed 1200 pounds within a period of one minute. Maintain that force for five minutes.
 - 6.2.1.2 Multiple Occupancy Swing Assembly - For swing assemblies intended for multiple occupancy, place a load distribution device on the center of each seat. Apply vertical downward force of 725 pounds to each loading device simultaneously. Apply the force gradually until it attains but does not exceed 725 pounds per device within a period of one minute. Maintain that force for five minutes.
 - 6.2.1.3 Trapeze Bar - For swing assemblies consisting of a trapeze bar or ring, place a loading strap on the center of the trapeze bar or ring and apply a vertical downward force of 1200 pounds. Apply the force gradually, until it attains but does not exceed 1200 pounds within a period of one minute. Maintain that force for five minutes.
 - 6.2.1.4 One Foot Support - Test individually foot supports that are intended to support only one foot (similar to the example shown in Figure 2). Place a load distribution device centered on the position intended to support a user's foot and apply a vertical downward force of 484 pounds. Apply the force gradually, until it attains but does not exceed 484 pounds within a period of one minute. Maintain that force for five minutes.
 - 6.2.1.5 Both Feet Support - For foot supports that are intended to support both feet (similar to the example shown in Figure 3) place a load distribution device centered in the position intended to support each user's feet. Apply vertical downward force of 725 pounds gradually, until it attains but does not exceed 725 pounds per device within a period of one minute. Maintain that force for five minutes.

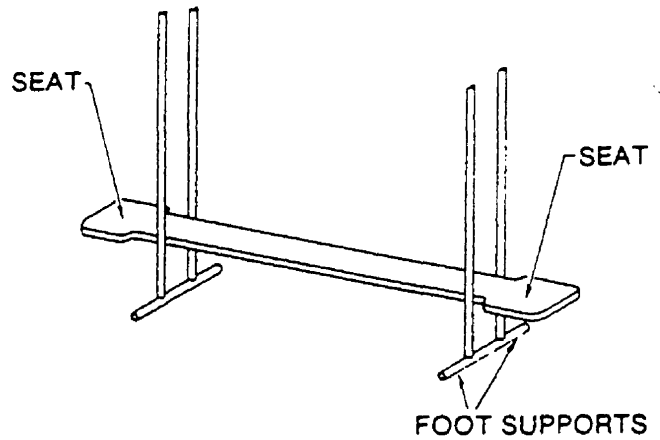

FIGURE 2 - FOOT SUPPORT INTENDED TO SUPPORT ONE FOOT

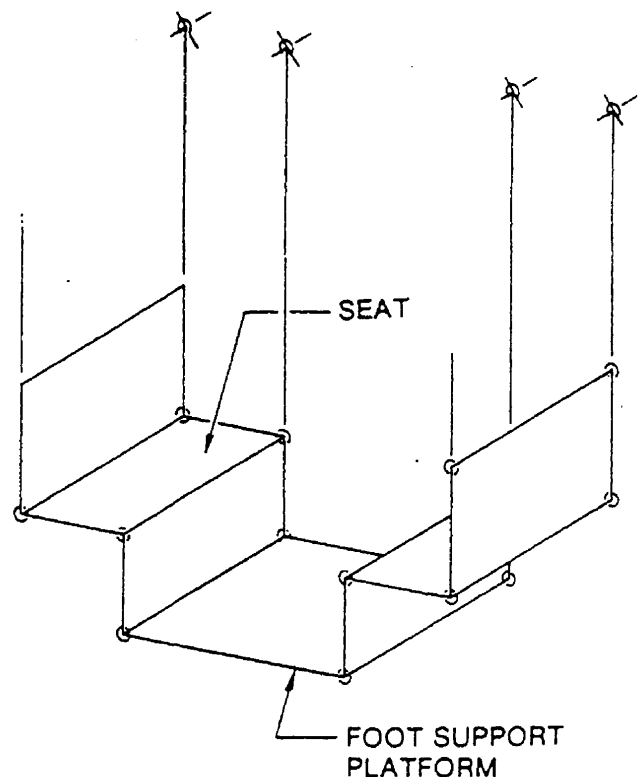
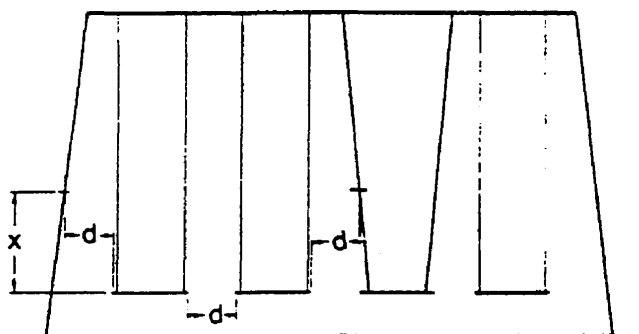

FIGURE 3 - FOOT SUPPORT INTENDED TO SUPPORT BOTH FEET

Structures Supporting Swing Assemblies - 6.2.1.6
 Center an appropriate load distribution device at each occupant position on all swing assemblies. Simultaneously, load each load distribution device with the force specified in Table 1.

TABLE 1		
Type of Swing Assembly	Vertical Downward Force in Pounds to Be Applied Per Load Distribution Device	
	Structures Supporting One Assembly	Structures Supporting Two or More Assemblies
Single occupancy swing assembly	1200	900
Multiple occupancy swing assembly	725	600

6.2.1.7 Minimum Clearance of Suspended Members - The recommended minimum clearance between adjacent suspended members and between a suspended member and the adjacent supporting structure should not be less than 18 inches when measured as shown in Figure 4.



d=18 inches minimum
x=33 inches minimum

FIGURE 4 - SWING CLEARANCE MEASUREMENT

6.2.2 Components and Structures Subjected to Vertical Loads - Estimate the number of simultaneous users, N, of a component or structure as specified in Paragraphs 6.2.2.1 through 6.2.2.6 of this section. Place N load distribution devices on the component or structure in a manner that simulates the anticipated load distribution. Simultaneously, load each load distribution device with a vertical downward force F_t given by the following equation:

$$F_t \text{ (pounds)} = 300 (N + 1)/N$$

6.2.2.1 Individual Longitudinal Components - Measure the length of the component, L (in inches), and determine N from Table 2.

NOTE: It is sufficient to test one of several components identical in size, material and method of construction.

NOTE: Components such as side pieces of ladders, top support bar or pipe of swing assemblies and the like, with the obvious main function of supporting other components, need not be tested by this procedure.

TABLE 2	
Length of the Component in Inches	Estimated Number of Users
$L < 24$	$N = 1$
$24 \leq L < 88$	$N = L/16$
$L \geq 88$	$N = (L + 72)/32$
	Where necessary, round off to the nearest integer. Round up if the fractional part is .5.

6.2.2.2 Structures Containing Two or More Longitudinal Components - Count the number of longitudinal components, L, and determine N from Table 3.

TABLE 3	
Number of Longitudinal Components	Estimated Number of Users
$L \leq 5$	$N = L$
$L > 5$	$N = (L + 5)/2$ When N is not an integer, round down to the next integer.

6.2.2.3 Individual Surfaces - For playground equipment such as decks, platforms, ramps, stair steps, or the like, compute the surface area, A (in square feet), and determine N from Table 4.

TABLE 4	
Area of the Surface in Square Feet	Estimated Number of Users
$A \leq 1$	$N = 1$
$1 < A \leq 10$	$N = A$
$A > 10$	$N = (A + 10)/2$
	Where necessary, round off to the nearest integer. Round up if the fractional part is .5.

Apply a 460 pound ~~horizontal~~ force to the load distribution device in a direction perpendicular to the length of the component and away from the enclosed structure.

6.2.3.2 Distributed Load - Apply a horizontal force, F, in a direction perpendicular to the length of the component and away from the enclosed structure. Apply the force near the top of the component and evenly distributed over the entire length of the component.

The test force is given by: $F(\text{pounds}) = 150L$, where L is the length of the component in feet.

6.2.2.4 Structures Supporting Two or More Surfaces - Estimate the number of users, N, for each surface from Table 4. Obtain N by adding the estimates for each surface:

$$N = N_1 + N_2 + N_3 \dots$$

6.2.2.5 Slide Beds - Estimate the number of users, N, as follows:

$$N = L/36,$$

where L is the length of the slide bed in inches.

6.2.2.6 Other Structures - For other structures such as merry-go-rounds, see-saws, spring rockers or the like, estimate the number of simultaneous users, N, as follows:

6.2.2.6.1 With Designated Occupancy - For apparatus with designated occupancy arrangements, N is equal to the number of designated occupancies.

6.2.2.6.2 Without Designated Occupancy - For apparatus without designated occupancy arrangements, make a reasonable estimate of N, including allowances for possible overloading.

6.2.3 Components Subjected to Lateral Loads - Components subjected to lateral loads such as guard rails, handrails, sides of barriers and enclosures, and the like, should be subjected to the two separate tests described below.

6.2.3.1 Concentrated Load - Place an appropriate load distribution device on the component at any point to produce the most adverse effect.

7. Sharp Points, Corners and Edges; Pinch and Crush Points; Protrusions; Suspended Hazards

7.1 Sharp Points, Corners and Edges - Assemble in accordance with accompanying instructions. It is recommended that there be no accessible sharp edges or points that can cut or puncture human tissue. The exposed open ends of all tubing not resting on the ground, or otherwise covered, should be provided with caps or plugs that cannot be removed without the use of tools. Smooth finished caps, covers, or the equivalent, should be provided for the purpose of covering accessible bolt ends. When properly torqued, the recommended length of the protruding bolt end should be such that the cap or covering fits against the nut or surrounding surface. The caps or coverings should not be removable without the use of tools.

NOTE: If the edge or point is questionable in terms of its injury potential, it should be considered as being sharp. A minimum

radius of curvature of one-quarter inch is recommended for corners and edges of suspended members. This section does not apply to belts, straps, ropes and similar flexible components.

Pinch and Crush Points - There should be no accessible pinch, crush or shear points caused by components moving relative to each other or to a fixed component when the equipment is moved through its anticipated use cycle. To determine if there is a possible pinch or crush point, consider the likelihood of entrapping a body appendage and the configuration and closing force of the components.

Protrusions - The following recommendations and suggested test procedures to measure protrusions are based on National Bureau of Standards reports submitted to CPSC. (See References 29 and 30).

Recommendation - When tested in accordance with Paragraph 7.3.2, no protrusion should extend beyond the face of any of the three gauges having dimensions shown in Figure 5.

7.2

7.3

7.3.1

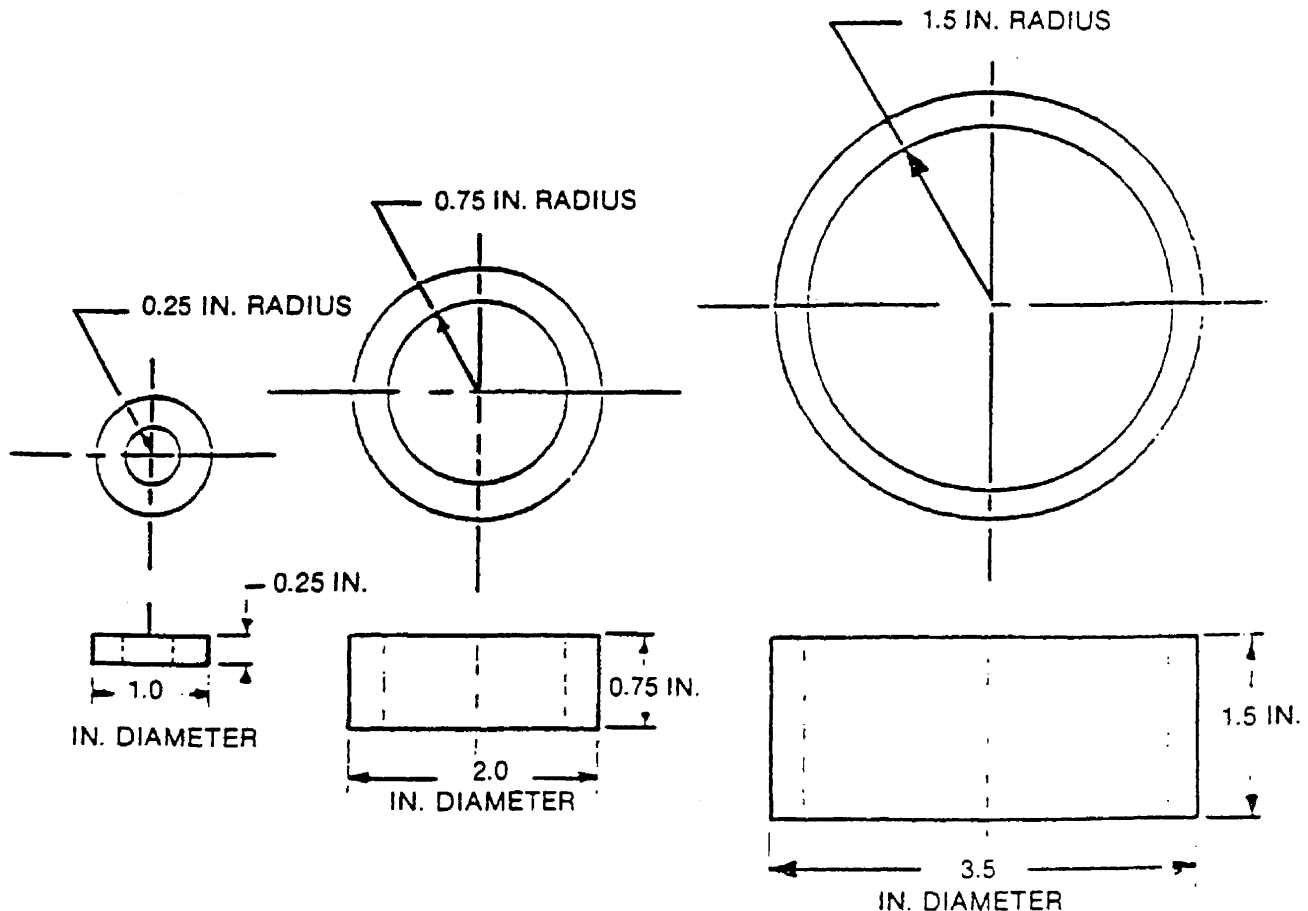

FIGURE 5 - PROTRUSION TEST GAUGES

7.3.2 Suggested Test Method - Successively place each gauge (see Figure 6) over each protrusion to determine if the protrusion extends beyond the face of the gauge.

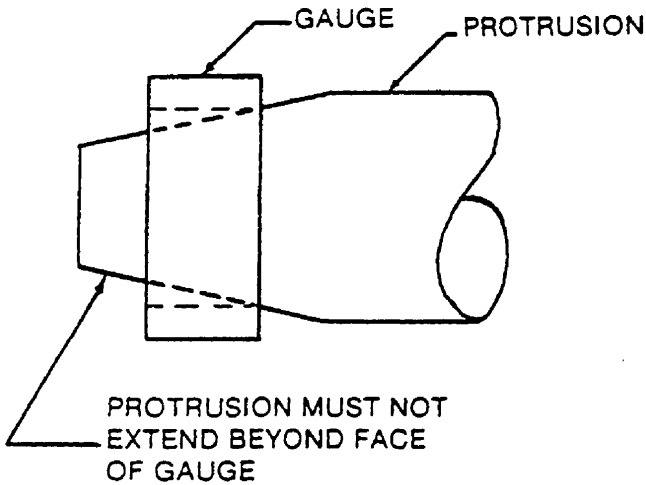

FIGURE 6 - PROTRUSION TEST

7.3.3 Exclusions - The above suggested test method does not apply to the following:

7.3.3.1 Inaccessible Protrusions - (except those that may be contacted by a child falling from the equipment).

7.3.3.2 Protrusions on the Front and Rear Surfaces of Suspended Members of Swing Assemblies.

7.3.3.2.1 Recommendation - When tested in accordance with Paragraph 7.3.3.2.2, no surface in the potential impact region should protrude through the hole beyond the face of the specified gauge.

7.3.3.2.2 Suggested Test Method - Conduct the test with the suspended member in its rest position.

Place the gauge shown in Figure 7 over any protrusions on the front and rear surface of the suspended member such that the axis of the hole is parallel to both the intended path of the suspended member and a horizontal plane.

Suspended Hazard - Cables, wires, ropes, or similar components suspended between other components within 45 degrees of the horizontal are not recommended because they could be impacted by a rapidly moving child. This recommendation does not include cables, ropes and other such items located 7 feet or more above the ground or equivalent surface.

7.4

NOTE: It is not the intent of this recommendation to eliminate items such as guard railings or series of ropes or cables such as cargo nets and climbing grids. This should be considered when evaluating a potential hazard.

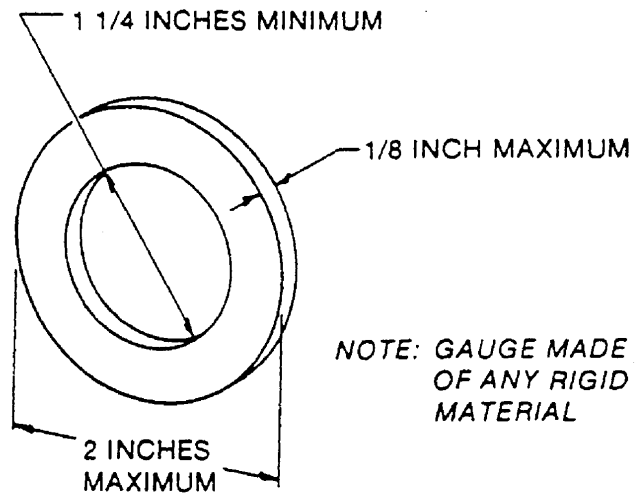
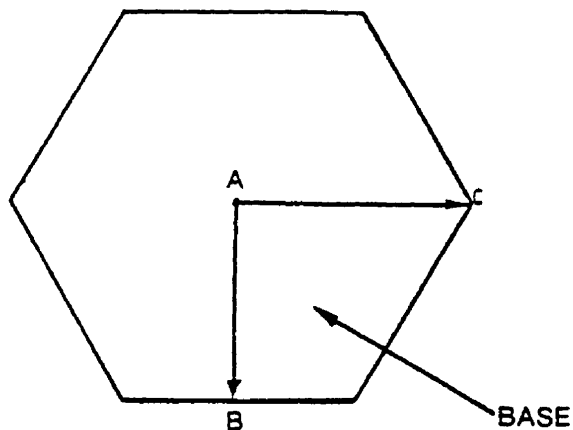

FIGURE 7 - PROTRUSION TEST GAUGE FOR SUSPENDED SWING ASSEMBLIES

8. Base Configuration of Rotating Equipment --- 9. Moving Impact of Swings

Recommendation - The rotating components of all rotating apparatus intended to support standing or seated users should incorporate a continuous base that meets the following:

- The surface of the base should be continuous with no opening between the axis and the periphery that permits a rod having a diameter of 0.3 inches to penetrate through the surface.
- No component of the apparatus should extend beyond the perimeter of the base.
- The difference between the minimum radius and the maximum radius of a non circular base should not exceed 2.0 inches (see Figure 8).



A = AXIS OF ROTATION
 AB = MINIMUM RADIUS
 AC = MAXIMUM RADIUS

THE DIFFERENCE BETWEEN DIMENSION AC AND AB SHOULD NOT EXCEED 2.0 INCHES.

FIGURE 8 - MINIMUM AND MAXIMUM RADII OF NON CIRCULAR BASE

Recommendation - When tested in accordance with suggested test method specified in Paragraph 9.2, a suspended member should not impart a peak acceleration in excess of 100 g's to the test headform (see Paragraph 9.2.2.1). This recommendation is intended to apply to any potential impact region of a suspended member having a clearance height of less than 64 inches (see Reference 29). **9.1**

Suggested Test Method. **9.2**

Ambient Laboratory Conditions - Ambient laboratory conditions are required for the test (62-82°F). Expose all test equipment and suspended members to these conditions for at least four hours prior to test. **9.2.1**

Test Equipment. **9.2.2**

Headform and Support Assembly - (See Reference 29). The peak acceleration imparted by a suspended member is determined by impacting an instrumented headform with the suspended member. The size "C" headform specified in the Federal Motor Vehicle Safety Standard No. 218 is used for this test. **9.2.2.1**

Construct the headform support assembly in such a manner that the total headform and support assembly weight does not exceed 10.5 pounds. Mount an accelerometer at the center of gravity (C.G.) of the headform and support assembly combination with the sensitive axis of the accelerometer aligned to within 5 degrees of the direction of travel of the headform.

Guidance Structure - The motion of the headform after impact must be restricted to horizontal travel with the headform centerline remaining in the central plane, as depicted in Figures 9, 9a, and 9b. Use a six-inch I-beam (6I 12.5 American Standard I-Beam) or an equivalent structure as the primary support structure to provide the required headform motion secured in such a manner that it is stationary during the test. The static coefficient of friction between the headform support assembly and the stationary guidance system structure must be less than 0.02. **9.2.2.2**

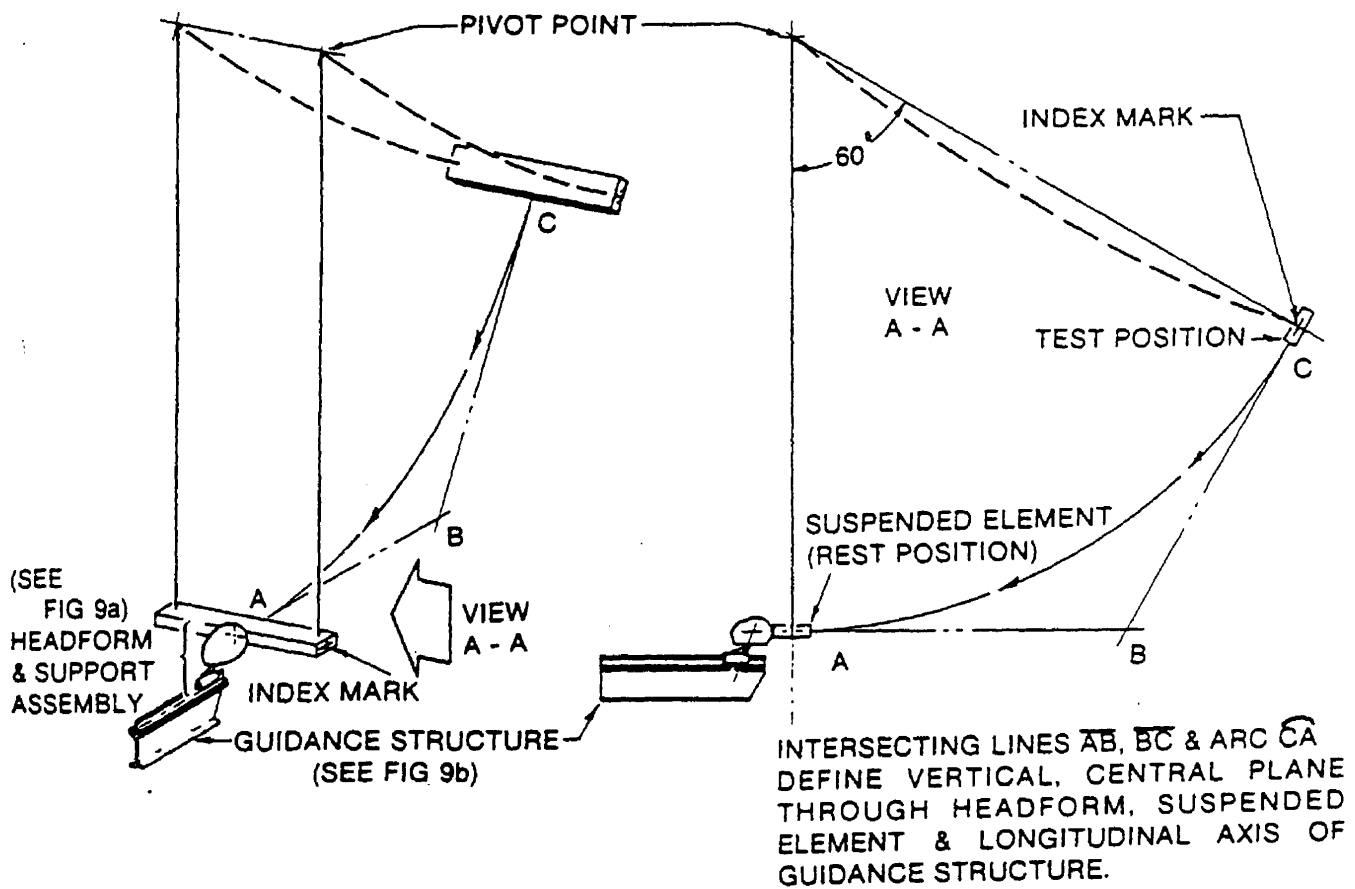

FIGURE 9 - IMPACT TEST SET-UP

IMPACT POINT

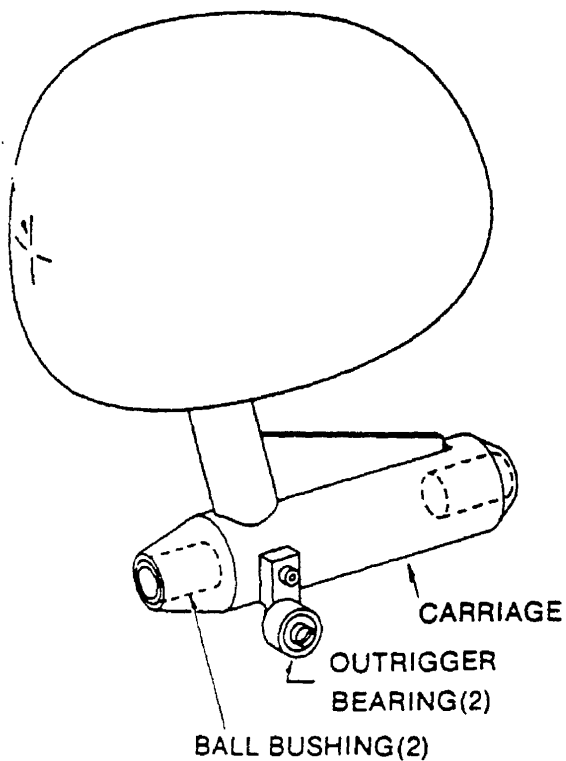

FIGURE 9a - HEADFORM & SUPPORT ASSEMBLY

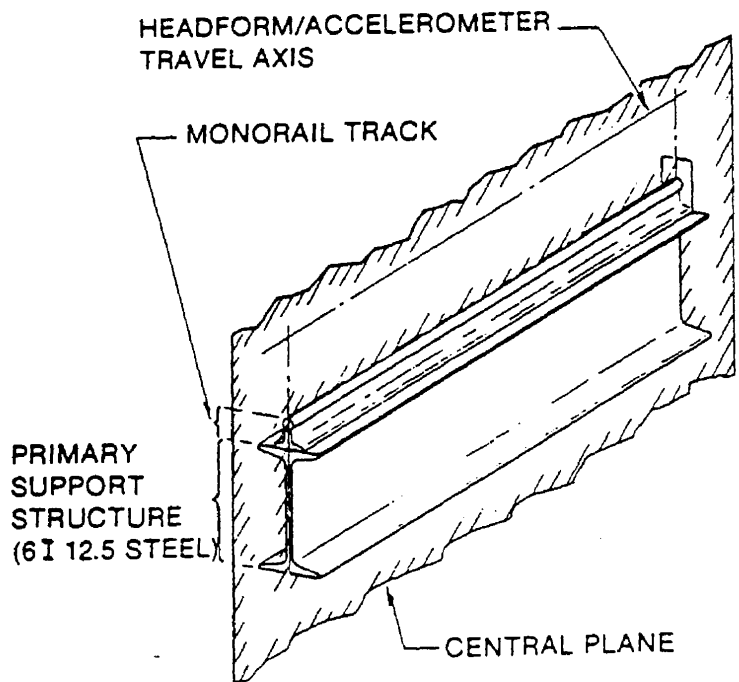

FIGURE 9b - GUIDANCE STRUCTURE

9.2.2.3 Instrumentation - Select and operate the instrumentation for this test, including accelerometer, signal conditioner and oscilloscope, according to SAE Practice J211, Channel Class 1000.

9.2.3 Step 1. Index Mark - Affix an index mark to the side of the suspended member to indicate its mass center (C.G.) projection in the side view. To determine the location of the index mark, the suspended member must be suspended in two successive alternate positions as illustrated in Figure 10. The mark location is determined by the intersection of the projection of vertical lines passing through the suspension point (see Figure 10) when the member is suspended at the successive alternate positions.

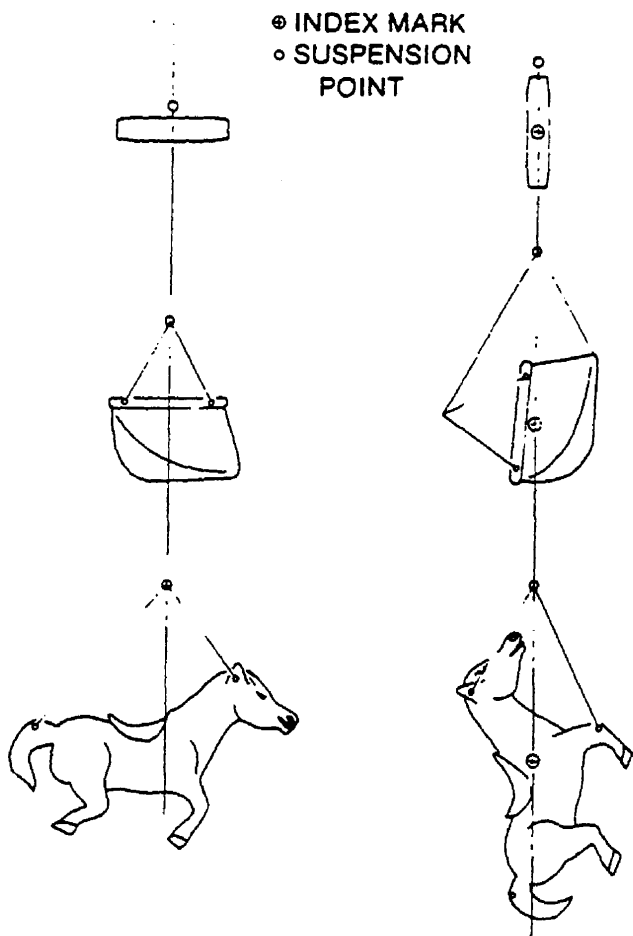

FIGURE 10 - TYPICAL INDEX MARK DETERMINATIONS

NOTE: Flexible belt-type suspended members require a brace (see Figure 10a) to maintain seat configuration during this procedure and during impact testing. The weight of the brace must not ex-

ceed 10% of the weight of the suspended member.

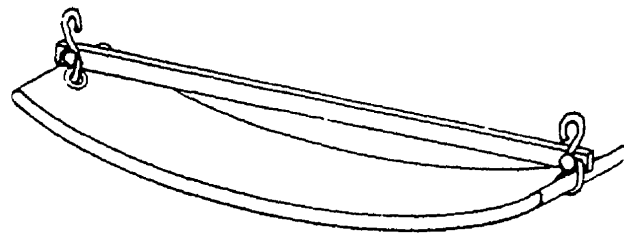

FIGURE 10a - BRACE FOR FLEXIBLE SEATS

Step 2. Assembly and Installation - Assemble and install the suspended member to be tested according to the accompanying instructions, using the hardware and the maximum length suspending elements supplied with, or specified for, the equipment.

9.2.4

Step 3. Position of Suspended Member - Allow the suspended member to assume its free hanging rest position (refer to Figure 9) and adjust the relative positions of the suspended member, headform, and guidance system to meet the following conditions:

9.2.5

- The centerlines of the headform and guidance structure, and the impact point of the suspended member must lie in the central plane.
- The lower edge of the headform must be horizontal, with the headform contacting the impacting surface of the suspended member.
- The suspended member's impacting point shall be in line with, and adjacent to, the impact point on the headform. The impact point is that point on the headform which lies in the central plane and is tangent to the vertical.

Step 4. Placement of Suspended Member - Place the suspended member in the test position indicated by one of the following methods.

9.2.6

Test Position 1 - Raise suspended members which are supported by chains, ropes, cables or other non-rigid suspending elements along their arc of travel until the side view projection of a straight line through the pivot point and index mark forms an angle of 60 degrees with the vertical. Once the suspended member is raised to the test position, some curvature will be produced in the suspending elements. Adjust the suspended member position to de-

9.2.6.1

termine that curvature which provides a stable trajectory.

- 9.2.6.2 Test Position 2 - Elevate the suspended members which are supported by rigid suspending elements along their arc of travel until the side view projection of the suspending element, which was vertical in the rest position, is at an angle of 60 degrees with the vertical, or at the maximum angle attainable, whichever is less.
- 9.2.6.3 Additional Instructions - In the use of either of the test positions specified in Paragraphs 9.2.6.1 and 9.2.6.2 above, caution should be exercised to prevent damage to the test equipment. If an unusually heavy or hard suspended member is to be tested, preliminary tests should be made at lower test angles (e.g. 10 degrees, 20 degrees, 30 degrees, etc.) If the recommendations of Paragraph 9.1 are exceeded at a lower test angle than that specified in Paragraphs 9.2.6.1 or 9.2.6.2, the member does not agree with the guidelines and no further tests are necessary. Additionally, if there is doubt concerning the suspended member trajectory or stability, the headform and/or guidance structure should be set aside to allow trial releases without impacting the headform.
- 9.2.7 Step 5. Support of Suspended Member - Support the suspended member in the test position by a mechanism that provides release without the application of external forces which would disturb the trajectory of the suspended member. Prior to release, the suspended member and suspending elements must be motionless. Upon release, the assembly must travel in a smooth downward arc without any visible oscillations or rotations of the suspended member which will prevent it from striking the headform at the impact point.
- 9.2.8 Step 6. Collection of Data - Once satisfactory system operation and calibration are obtained, collect data for ten impacts. Measure the peak acceleration in g's for each impact. If the data for any two of the ten impacts do not meet the recommendations of Paragraph 9.1, the suspended member does not agree with the guidelines.

10. Entrapment

General - To ensure that a child's arms, hands, or other body parts cannot become lodged in the equipment when the momentum of the child or equipment is sufficient to cause injury or a loss of balance, accessible components of moving apparatus and components adjacent to sliding surfaces (protective barriers, sides, handrails, etc.) should not be of a configuration that can entrap any part of a user's body. 10.1

Head Entrapment - To prevent a component or group of components from forming an angle or opening that can trap a user's head, the following guidelines are recommended for angles and openings that are accessible in accordance with Paragraph 10.2.2. 10.2

Recommendations. 10.2.1

Angles - Angles formed by adjacent surfaces (see Figure 11) on the boundary of an accessible opening, should exceed 55 degrees. 10.2.1.1

Distance - The distance between two opposing interior surfaces forming the boundary of an accessible opening should not be less than 7 inches when measured perpendicular to each surface (see Figure 12). 10.2.1.2

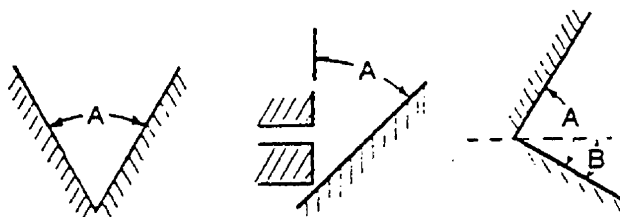

ANGLE A SHOULD EXCEED 55°. ANGLE A IS EXCLUDED IF ANGLE B IS MORE THAN 10° BELOW HORIZONTAL.

FIGURE 11 - ANGLES OF ACCESSIBLE OPENINGS

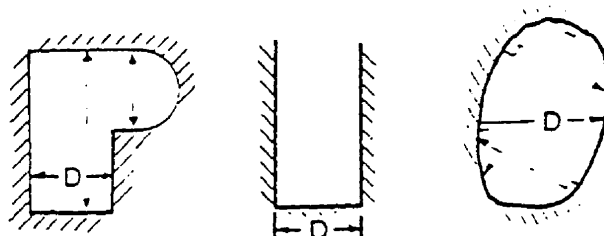

DISTANCE D SHOULD NOT BE LESS THAN 7 INCHES

FIGURE 12 - PERPENDICULAR DISTANCE BETWEEN OPPOSING SURFACES

10.2.1.3 Projected Lines of Intersection - For components that do not form a vertex as illustrated in Figure 13, the angle is determined from the projected lines of intersection. This angle should agree with the recommendation of Paragraph 10.2.1.1. Parallel surfaces should agree with the recommendation of Paragraph 10.2.1.2. For exception, see Paragraph 10.2.3.4.

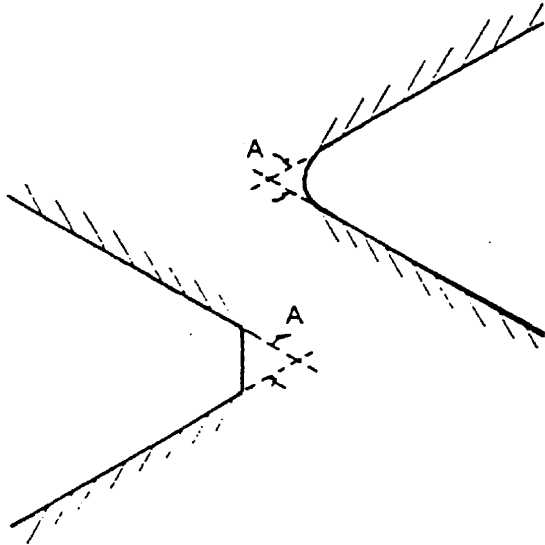

FIGURE 13 - PROJECTED LINES OF INTERSECTION FOR DETERMINING ANGLE A

10.2.2 Suggested Test Method - Attempt to insert a probe having dimensions as shown in Figure 14. If the probe penetrates an opening to a depth of at least 4 inches, or if the unbounded part of a partially bounded opening is at least 1.75 inches wide (see Figure 15) the opening can be considered accessible. If the opening meets the recommendations of Paragraph 10.2.1, it agrees with the guidelines.

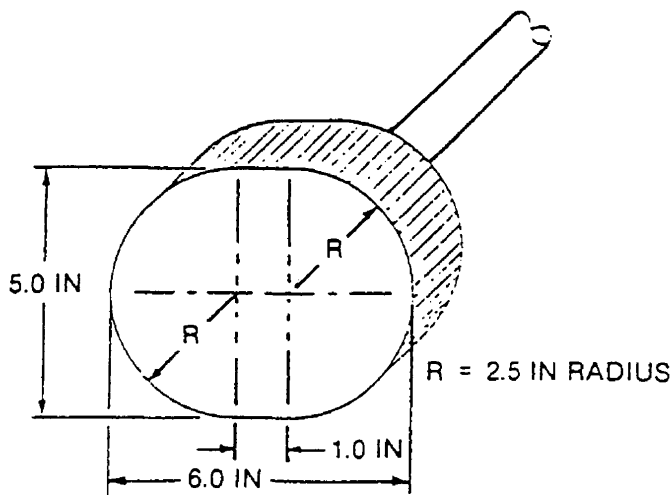

FIGURE 14 - PROBE FOR DETERMINING ACCESSIBLE OPENINGS

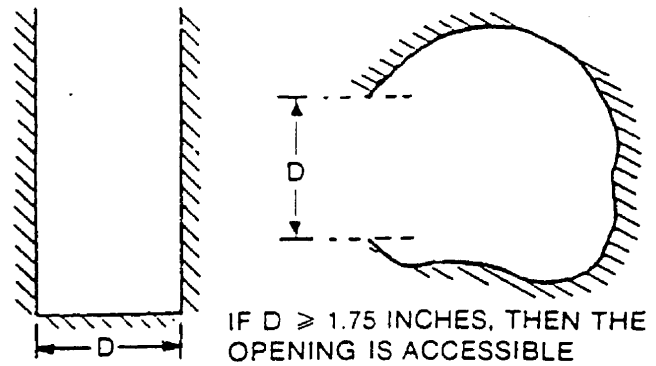

FIGURE 15 - PARTIALLY BOUNDED OPENINGS

Exceptions to Paragraph 10.2.1.

10.2.3

Exception 1 - Angles less than 55 degrees with a lower leg projecting more than 10 degrees below horizontal.

10.2.3.1

Exception 2 - Angles and portions of accessible openings less than 24 inches above the ground or similar surface which provides the same opportunity as the ground for supporting the body.

10.2.3.2

Exception 3 - Accessible openings that are completely unbounded by a lower surface (see Figure 16).

10.2.3.3

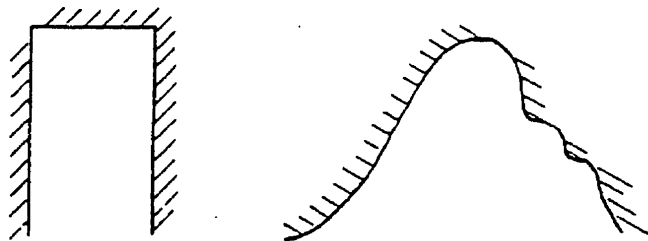

FIGURE 16 - UNBOUNDED LOWER SURFACE EXCLUSION

Exception 4 - Angles less than 55 degrees that have been filled or similarly covered such that the recommendation of Paragraph 10.2.1.2 of this section is met (see Figure 17).

10.2.3.4

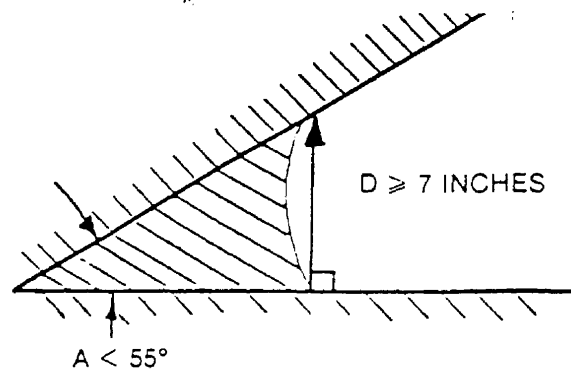

FIGURE 17 - LESS THAN 55° ANGLE EXCLUSION

11. Falls From Equipment

- 11.1 Elevated Surfaces** - It is recommended that an elevated surface located more than 30 inches above the underlying surface and intended for use as a platform, deck, walkway, landing, transitional surface, or similar walking surface have a protective barrier at least 38 inches in height. The protective barrier should completely surround the surface except for necessary entrance and exit openings. The intent of this recommendation is to prevent falls through the barrier, preclude the possibility of entrapment and discourage climbing.

NOTE: This recommendation is not intended to apply to elevated surfaces where a protective barrier would encumber the normal intended use of the apparatus. For example, balance beams, most climbing apparatus, platforms or other equipment tiered or layered in a manner which would preclude a fall of more than 30 inches. Note, also, that slides, ladders, and stairways are discussed separately.

- 11.2 Hand Gripping Components** - It is recommended that components intended to be grasped by the hands, such as rungs of horizontal ladders, climbing bars, hand rails, and the like, should not exceed 1.6 inches in diameter or in the maximum cross-sectional dimension (see Reference 30).

NOTE: This recommendation is based on anthropometric data relevant to a minimum user (hand size of a five year old child) and is intended as a guide.

When structural requirements cannot reasonably be met by 1.6 inch diameter components, care must be exercised in selecting alternate components and/or designs to insure that the hand gripping potential is not seriously impaired.

- 11.3 Ladders and Stairways** - The following recommendations are given:
- 11.3.1 For Slope** - When measured from a horizontal plane:
 - 11.3.1.1 Ladders with Rungs** - Ladders with rungs should have a slope between 75 and 90 degrees.
 - 11.3.1.2 Ladders with Steps** - Ladders with steps should have a slope between 50 and 75 degrees.
 - 11.3.1.3 Stairways** - Stairways should have a slope no

greater than 35 degrees.

For Steps and Rungs.

Horizontality - Steps and rungs should be horizontal (± 2 degrees).

Width - Steps and rungs should be at least 15 inches wide (see Figure 18).

$D \geq 3$ INCHES, IF RISERS ARE OPEN
 $D \geq 6$ INCHES, IF RISERS ARE CLOSED

7 INCHES $\leq H \leq 11$ INCHES
 $L = 15$ INCHES MINIMUM

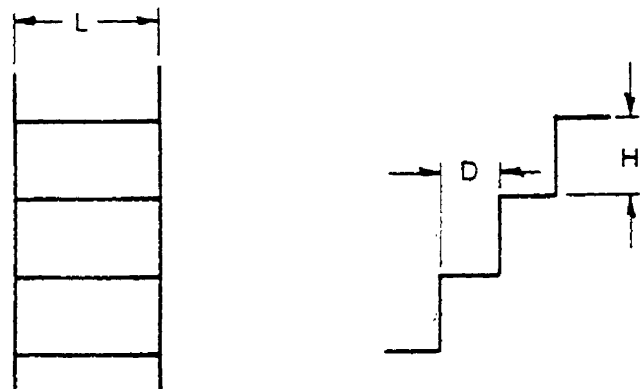

FRONT - ELEVATION - SIDE

FIGURE 18 - STEPS AND RUNGS

Spacing - Steps and rungs should be evenly spaced. The spacing, when measured between the top surfaces of two consecutive steps or rungs, should be between 7 and 11 inches (see Figure 18).

Tread Depth - Steps should have a tread depth of 3 inches or more if the risers are open and 6 inches or more if the risers are closed (see Figure 18).

For Hand Rails - Stairways and ladders with steps should have continuous hand rails on both sides. The railings should be designed to maintain the user in an upright position over each step.

Slip-Resistant Surfaces - It is recommended that components intended primarily for use by the feet should have a finish that is slip-resistant under wet and dry conditions.

Straight Slides - The following recommendations are given:

For Side Height - Sides should project at least

11.3.2

11.3.2.1

11.3.2.2

11.3.2.3

11.3.2.4

11.3.3

11.4

11.5

11.5.1

2.5 inches above the sliding surface when measured perpendicular to that surface (see Figure 19). The sides should extend for the entire length of the sliding surface.

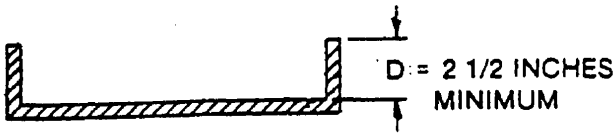
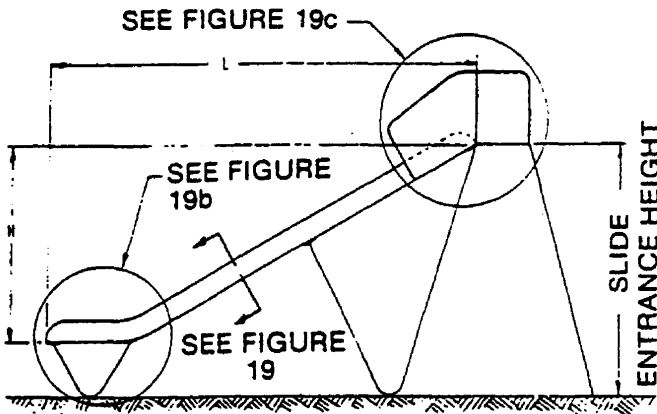

FIGURE 19 - SLIDE CROSS SECTION

11.5.2 For Slide Surface Slope.

11.5.2.1 Average Incline - The average incline of the sliding surface should not exceed 30 degrees as measured in accordance with Figure 19a.



NOTE: AVERAGE SLOPE SHOULD NOT EXCEED 30° OR $H/L \leq 0.577$

FIGURE 19a - STRAIGHT SLIDE

11.5.2.2 Span - No span of the sliding surface should have a slope that exceeds 45 degrees as measured from a horizontal plane.

11.5.3 For Exit Region: Slope, Length, Height and Radius of Curvature - The recommendations of this subsection pertain to slides having a vertical drop height (H) or an entrance height (see Figure 19a) in excess of 4 feet. (Slides having a vertical drop height (H) or entrance height 4 feet or less are not subject to these guidelines).

11.5.3.1 Slope - The slope of the exit region should be between 0 and -4 degrees as measured from a plane parallel to the underlying surface (see Figure 19b).

$X = 16$ INCHES MINIMUM

9 INCHES $\leq Y \leq 15$ INCHES

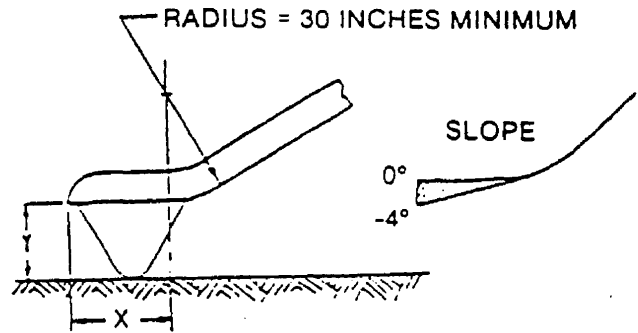

FIGURE 19b - EXIT REGION

Length - The exit surface of the slide should be at least 16 inches in length (see Figure 19b). **11.5.3.2**

Height - The exit surface should be at least 9 inches and no more than 15 inches above ground level (see Figure 19b). **11.5.3.3**

Radius - The radius of curvature of the sliding surface in the exit region should be at least 30 inches when measured as shown in Figure 19b. **11.5.3.4**

For Slide Surface Entrance - All slides should have features that facilitate transition to the inclined sliding surface. Slides having an entrance height of more than 30 inches should meet the following: **11.5.4**

Platform - The entrance to the inclined sliding surface should be a horizontal platform at least 10 inches in length and at least as wide as the contiguous inclined surface. **11.5.4.1**

Protective Barriers - Except for necessary exit and entrance openings, a barrier should completely surround the platform and extend down the sides of the inclined surface in accordance with minimum dimensions provided in Figure 19c. **11.5.4.2**

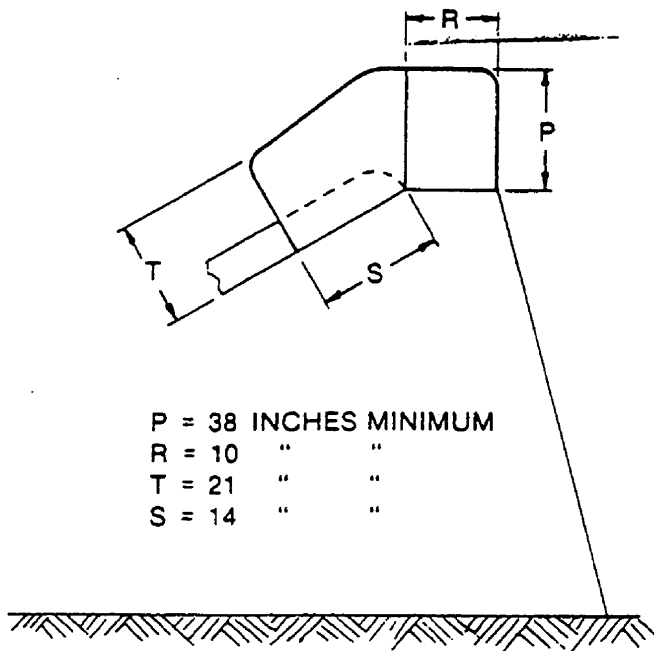

FIGURE 19c - SLIDE SURFACE ENTRANCE

11.5.4.2.1 To Maintain Body Balance - The barrier should provide the facility for the minimum as well as maximum user to maintain body balance and support when moving through the transition between ladder, platform, and sliding surface.

11.5.4.2.2 Prevention of Falls - The protective barrier should prevent falls through the barrier, preclude the possibility of entrapment and be of a design that neither encourages nor facilitates climbing.

NOTE: These recommendations may not be appropriate for all types of slides, e.g., slides built into a hill, extra wide slides that can accommodate more than a single user, or tubular (totally enclosed) slides.

11.6 Spiral Slides - Spiral slides, an example of which is shown in Figure 20, should be designed and constructed so as to prevent lateral discharge of the slider from the chute. Lateral discharge may occur in one of two ways, by tipping over or by sliding over the outer edge or by tipping over or sliding over the inner edge. To prevent these types of lateral discharge, follow the recommendations in Paragraphs 11.6.1 through 11.6.6.

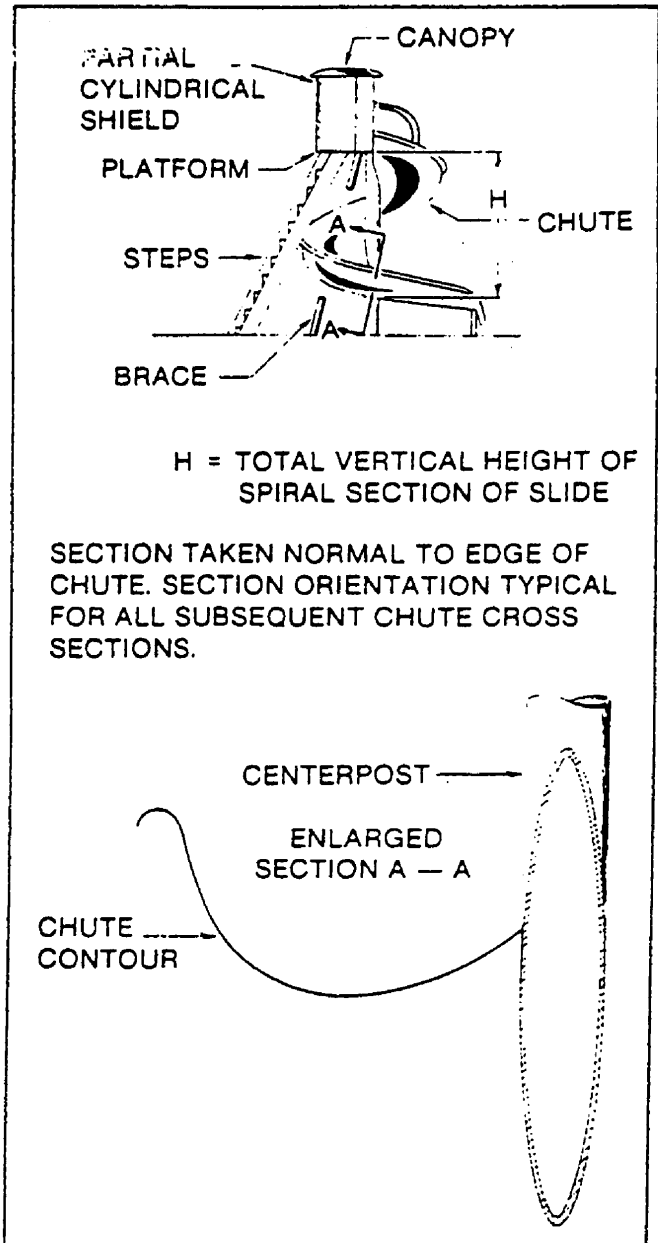

FIGURE 20 - SLIDE'S BASIC CONSTRUCTION, "H" & CHUTE CROSS SECTION

11.6.1 Lateral Discharge Mode by Tipping Over Outer Edge - This mode of lateral discharge may occur if the contour of a cross section of the chute is composed of perpendicular lines as shown in Figure 21a or has an abrupt change in contour as shown in Figure 21b. For such a spiral slide to prevent lateral discharge of the slider, the height of the outer edge of the chute, Y, must be equal to or greater than a value that is a function of the height of the spiral section of the slide (H in Figure 20), the radius of curvature of the turn (R), and the banking angle of the chute (θ) (see Paragraph 11.6.5.1 for computation of Y).

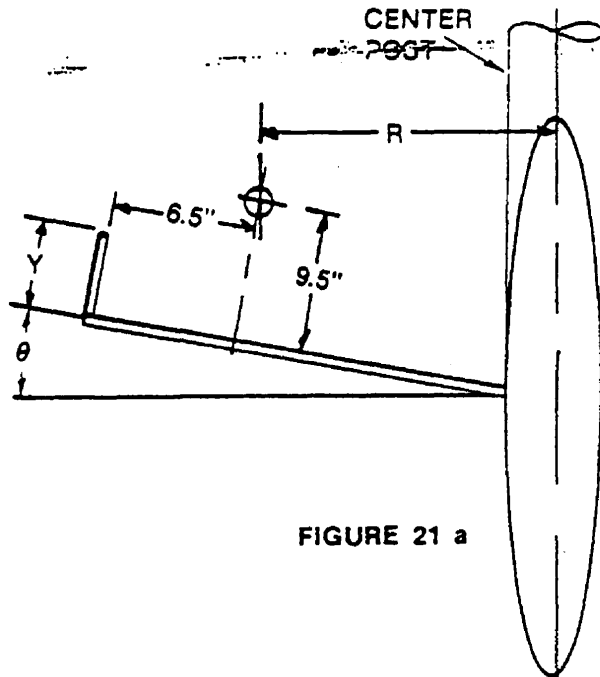

FIGURE 21 a

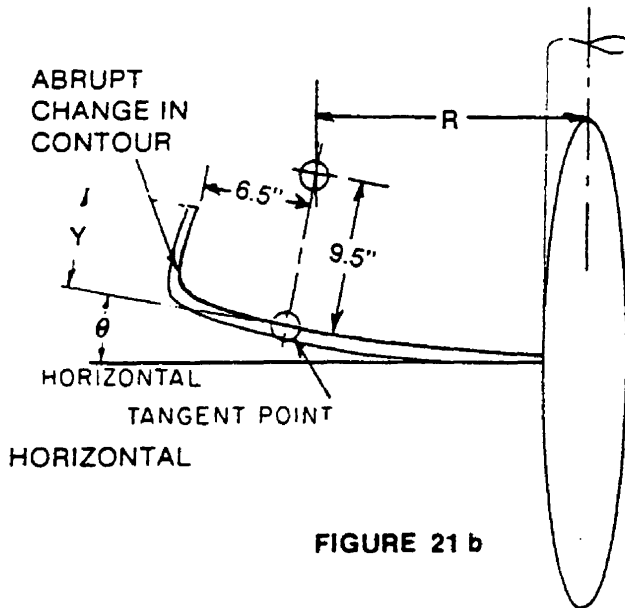
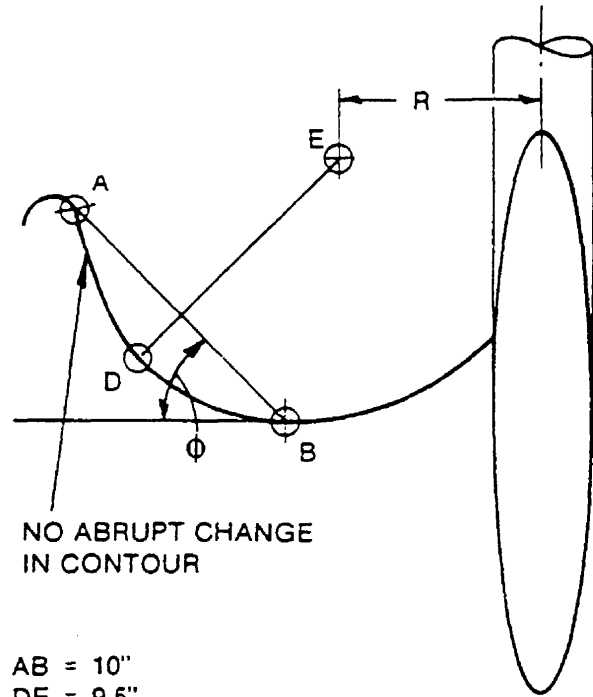

FIGURE 21 b

Y = HEIGHT OF OUTER EDGE OF CHUTE
 R = RADIUS OF CURVATURE OF TURN
 θ = BANKING ANGLE OF CHUTE

FIGURES 21a and 21b - CROSS SECTION OF CHUTES OF SPIRAL SLIDES WHOSE MODE OF LATERAL DISCHARGE IS TIPPING

Figure 22. For such a spiral slide to prevent lateral discharge of a slider, the effective banking angle, ϕ , must be equal to or greater than a value that is a function of the height of the spiral section, (H), and the radius of curvature of the turn, (R) (see Paragraph 11.6.5.2 for computation of ϕ).



NO ABRUPT CHANGE IN CONTOUR

AB = 10"
 DE = 9.5"
 AB \perp DE
 R = RADIUS OF CURVATURE OF TURN
 ϕ = EFFECTIVE BANKING ANGLE

FIGURE 22 - CROSS SECTION OF CHUTE WHOSE MODE OF LATERAL DISCHARGE IS SLIDING

11.6.2 Lateral Discharge Mode by Sliding Over Outer Edge - This mode of lateral discharge may occur if the contour of a cross section of the chute is a continuous curve with no abrupt change in curvature such as that shown in

11.3.3 Lateral Discharge Mode Over Outer Edge Not Obvious - For some chutes the potential mode of lateral discharge may not be obvious. In such cases, a radius gauge should be constructed similar to the one shown in Figure 23a. If the gauge contacts the chute contour at two points, such as shown in Figure 23b, the potential mode of lateral discharge will be tipping. If the gauge contacts the chute at only one point, such as is shown in Figure 23c, the potential mode of lateral discharge will be sliding.

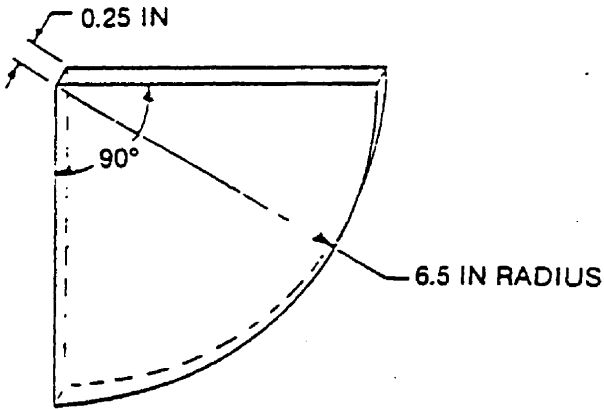
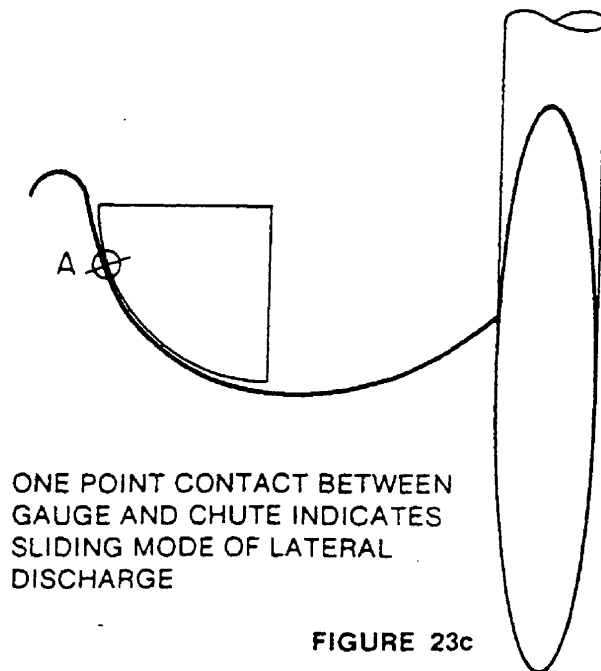
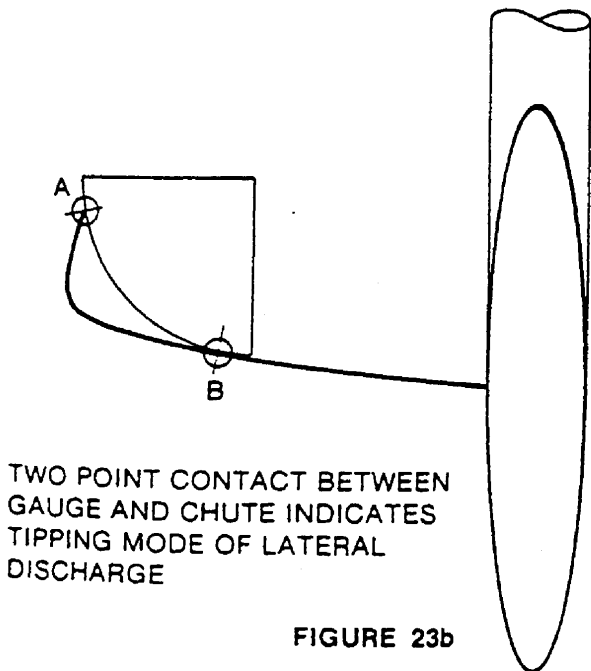

FIGURE 23a - RADIUS GAUGE TO DETERMINE POTENTIAL MODE OF LATERAL DISCHARGE FROM SPIRAL SLIDE



FIGURES 23b and 23c - USE OF RADIUS GAUGE TO DETERMINE POTENTIAL MODE OF LATERAL DISCHARGE

Determination of Factors to compute Outer Edge Discharge. 11.6.4

Maximum vertical drop of curved section of slide, (H) - Measure the vertical distance between the entrance to the slide and the lowest point on the spiral section of the chute (see Figure 20). 11.6.4.1

Radius of Curvature of the Turn, (R) - If the mode of lateral discharge is tipping, measure R as shown in Figures 21a or 21b. If the mode of lateral discharge is sliding, measure R as shown in Figure 22. 11.6.4.2

Measurement of Banking Angle, θ (theta), for Tipping Discharge Mode - If the mode of lateral discharge is tipping, measure θ as shown in Figures 21a or 21b. 11.6.4.3

Measurement of Effective Banking Angle, ϕ (phi), for Sliding Discharge Mode - If the mode of lateral discharge is sliding, measure ϕ as shown in Figure 22. 11.6.4.4

11.6.5 Computation of Parameters for Outer Edge Discharge.

11.6.5.1 Tipping - If the mode of lateral discharge is tipping, compute the effective edge height, Y, from the following expression:

$$Y \geq 9.5 - 6.5 \frac{1.6 (H/R) \text{TAN } \theta + 1}{1.6 (H/R) - \text{TAN } \theta}$$

NOTE: In no case should the effective edge height be less than 2.5 inches. Minimum values for Y have been computed for different values of H, R, and ϕ and are included in Tables 1 and 2.

11.6.5.2 Sliding - If the mode of lateral discharge is sliding, compute the effective banking angle, ϕ , from the following expression:

$$\phi \geq \text{TAN}^{-1} (1.6 H/R) - 11.3^\circ$$

NOTE: Minimum values for ϕ have been computed for different values of H and R and are included in Table 3.

TABLE 1. Minimum Effective Edge Heights, Y Inches: R = 15 Inches

$$Y = 9.5 - 6.5 \frac{1.6 (H/R) \text{TAN } \theta + 1}{1.6 (H/R) - \text{TAN } \theta}$$

H inches	θ degrees							
	0	10	15	20	25	30	35	40
	Y inches							
48	8.2	7.0	6.3	5.6	4.8	3.8	2.8	
60	8.5	7.3	6.6	5.9	5.1	4.3	3.3	
72	8.7	7.5	6.8	6.1	5.4	4.5	3.6	
84	8.8	7.6	7.0	6.3	5.5	4.7	3.8	2.7
96	8.9	7.7	7.0	6.4	5.7	4.9	3.9	2.9
108	8.9	7.8	7.1	6.5	5.8	5.0	4.1	3.0
120	9.0	7.8	7.2	6.5	5.8	5.0	4.2	3.1
132	9.0	7.9	7.3	6.0	5.9	5.1	4.2	3.2
144	9.1	7.9	7.3	6.6	5.9	5.2	4.3	3.3
156	9.1	8.0	7.3	6.7	6.0	5.2	4.3	3.3
168	9.1	8.0	7.4	6.7	6.0	5.3	4.4	3.4
180	9.2	8.0	7.4	6.7	6.0	5.3	4.4	3.4

TABLE 2. Minimum Effective Edge Heights, Y inches: R = 21 inches

$$Y = 9.5 - 6.5 \frac{1.6 (H/R) \text{ TAN } \theta + 1}{1.6 (H/R) - \text{TAN } \theta}$$

H inches	θ°	0	10	15	20	25	30	35	40
	Y inches								
48		7.7	6.4	5.7	5.0	4.0	2.9		
60		8.1	6.8	6.1	5.4	4.5	3.6		
72		8.3	7.1	6.4	5.7	4.9	4.0	2.9	
84		8.5	7.3	6.6	5.9	5.1	4.3	3.2	
96		8.6	7.4	6.8	6.1	5.3	4.5	3.5	
108		8.7	7.5	6.9	6.2	5.4	4.6	3.7	2.5
120		8.8	7.6	7.0	6.3	5.6	4.7	3.8	2.7
132		8.9	7.7	7.0	6.4	5.6	4.8	3.9	2.8
144		8.9	7.7	7.1	6.4	5.7	4.9	4.0	3.0
156		9.0	7.8	7.2	6.5	5.8	4.9	4.1	3.0
168		9.0	7.8	7.2	6.5	5.8	5.0	4.2	3.1
180		9.4	7.9	7.2	6.6	5.9	5.1	4.2	3.2

TABLE 3. Minimum Effective Banking Angle, ϕ°

$$\phi = \text{TAN}^{-1} (1.6 H/R) - 11.3^\circ$$

H inches	R inches			
	15	18	21	24
θ degrees				
48	68	66	63	61
60	70	68	66	65
72	71	70	68	67
84	72	71	70	69
96	73	72	71	70
108	74	73	72	71
120	74	73	72	76
132	75	74	73	72
144	75	74	73	73
156	75	75	74	73
168	76	75	74	74
180	76	75	75	74

11.6.6 Lateral Discharge Mode by Tipping or Sliding Over Inner Edge - When measured in accordance with Figures 24a and 24b, the contour of the chute at the inner portion should be such that

$$D \geq 2.5 \text{ INCHES}$$

NOTE: If the slide has a centerpost, it can be taken as the inner edge.

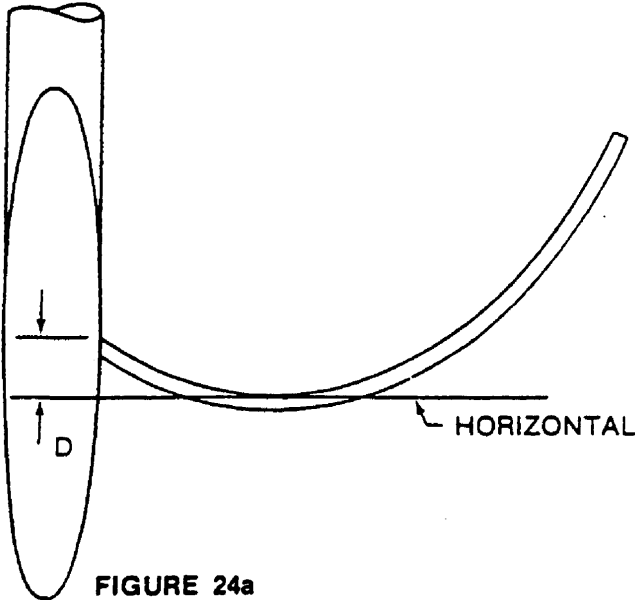

FIGURE 24a

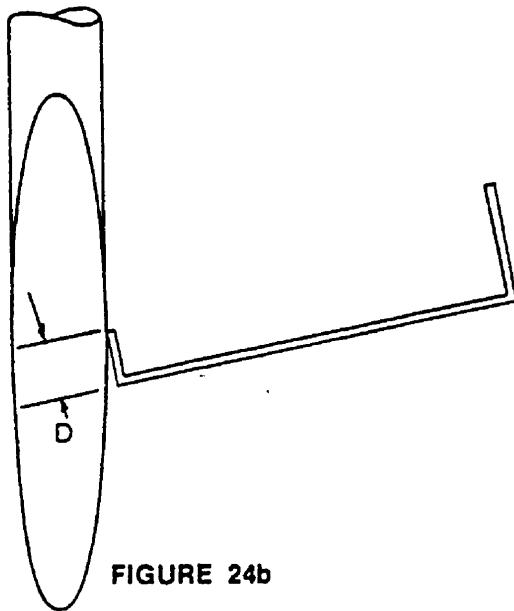

FIGURE 24b

FIGURES 24a and 24b - MEASUREMENT OF D

11.6.7 Exit Region: Slope, Length, Height and Radius of Curvature - Requirements of this section should be the same as those in Section 11.5.3.

11.6.8 Slide Surface Entrance - See Section 11.5.4.

12. Safety Guidelines for Surfaces Under Playground Equipment

Introductory Comments - The majority (60-70%) of public playground related injuries happen when children fall from the equipment and strike the underlying surface. Therefore, the objective of this section is to provide information about the relative ability of some surfaces to absorb the impact to a child's head, when the child falls. [The impact performance criterion for surfaces should be guided by head injury tolerance data for head-first falls of children (see Reference 32)].

12.1

Following are some types of surfaces commonly found in public playgrounds: blue stone dust (blue sandstone), crushed stone, cocoa shell mulch, pea gravel, pine bark mini-nuggets, pine bark mulch, rubber mats (both indoor and outdoor types), sand, shredded hardwood bark, synthetic turf on an asphalt base surface, tire mulch and paved surfaces such as asphalt, concrete, etc.

Generally, while hard surfacing materials such as macadam, black top, etc., may not require an excessive amount of maintenance or repair, they do not provide injury protection from accidental fall impacts and are therefore not recommended for use under playground equipment.

Soft surfacing materials, such as sand, pea gravel, bark, wood, rubber mulch, etc. which provide greater protection to the child, require continuous maintenance to retain their cushioning effectiveness.

Recommendation - When tested in accordance with the suggested test method in Paragraph 12.3, a surface should not impart a peak acceleration in excess of 200 g's to an instrumented ANSI headform dropped on a surface from the maximum estimated fall height (see Reference 32).

12.2

Suggested Test Method and Equipment - Use National Bureau of Standards' test method which requires dropping an instrumented headform in guided free fall and measuring some linear acceleration response of the headform during impact. For detailed procedures see Reference 32 for some applied surfaces and Reference 33 for soils.

12.3

Concrete, Asphalt and Similar Materials - Data obtained by the National Recreation and Park

12.4

Association and Roth and Burke (see Reference 1) and National Bureau of Standards (see Reference 33) indicated that even at low velocity impacts these materials would not meet the suggested 200 g criterion. **Because of this, it is suggested that all installation instructions and equipment catalogs contain statements recommending that paved surfaces, such as asphalt and concrete, not be used under playground equipment.**

12.5 Influence of Environment on Surfaces - In general, different surfacing materials are influenced by various environmental conditions existing in any specific location. Thus, selection of surfacing materials must take into account varying environmental factors. According to previous research, these surfaces generally can be affected by their environment as follows (see Reference 31):

12.5.1 Loose Materials.

12.5.1.1 Organic (e.g. pine bark mini-nuggets, pine bark mulch, shredded hardwood bark and cocoa shell mulch, etc.):

- The cushioning properties of these materials depend upon the air trapped within and between the individual particles. In rainy weather, or during periods of high humidity, these materials absorb moisture and tend to compact, thereby losing the trapped air necessary for protective cushioning.
- With the passage of time these materials decompose, are pulverized and become less cushioning.
- When wet and exposed to freezing temperatures, these materials will freeze and lose their cushioning protection.
- These materials, when wet, provide an ideal condition for micro-organism growth of various types which might allow transmission of communicable diseases.
- Wind blows these materials, reducing the thickness necessary for adequate cushioning.
- These materials may be blown or thrown into children's eyes.
- These materials are gradually displaced by the playing action of children, thereby reducing the thickness of protective layers in vital fall areas.
- These materials may harbor and conceal

various insects, animal excrement and other trash such as broken glass, nails, pencils and other sharp objects that can cause puncture and cutting wounds.

- With use, these materials may combine with dirt and other foreign materials resulting in a loss of cushioning properties.
- Generally, these materials require replacement and continuous maintenance such as leveling, grading, and sifting to remove foreign matter in order to remain effective as cushioning materials.

Inorganic (e.g. sand, pea gravel, blue stone dust (blue sandstone) crushed stone, etc.): **12.5.1.2**

- These materials could be blown or thrown into children's eyes.
- These materials could be displaced by the playing action of children, thereby reducing the thickness of protective layers in vital fall areas.
- These materials could harbor and conceal various insects, animal excrement and other trash such as broken glass, nails, pencils and other sharp objects that can cause puncture and cutting wounds.
- With use, these materials may be combined with dirt and other foreign materials, resulting in a loss of cushioning properties.
- With increasing amounts of moisture, sand becomes cohesive and less cushioning. When thoroughly wet, sand reacts as a rigid material when impacted from any direction.
- When wet and exposed to freezing temperatures, these materials will freeze and lose their cushioning protection.
- Pea gravel is difficult to walk on.
- Generally, these materials require replacement and continuous maintenance such as leveling, grading, and sifting to remove foreign matter in order to remain effective as cushioning materials.

Compact Materials (e.g. rubber mat - outdoor type, gym mat - indoor type, synthetic turf on asphalt base - stadium surface, etc.) (see Reference 32): **12.5.2**

- These materials have to be used on almost level uniform surfaces.
- These materials may be subject to vandalism

(defaced, ignited, cut, etc).

- Their performance will depend on the foundation or surface on which they are installed.

12.5.3 Soils - In general, the soils tested produced lower peak accelerations than asphalt but not as low as most of the loose surfacing materials (6 inches in depth) which were tested in the laboratory (see Reference 33). However, a perspective of test conditions must be maintained

when making these comparisons. The soils were tested in-situ, but none of the loose materials were tested under conditions of a playground environment. Peak acceleration appears to be correlated with a soil's moisture content; other associations are not evidenced by the data gathered by NBS. This is not surprising in view of the limited number of soils tested, the large number of variables that characterize a soil, and the compounding of these variables in the soils tested.

REFERENCES

1. NRPA, "Proposed Safety Standards for Public Playground Equipment and Supporting Rationale," submitted by NRPA (National Recreation and Parks Association) to CPSC, May 1976.
2. McConel, W.H., et al., "Product Investigation Report Contract No. FDA73-6, Public Playground Equipment," October 15, 1973.
3. Douglass, J.M., Nahm, A.M., and Roberts, S.B., "Applications of Experimental Head Injury Research," Proc. 12th Stapp Car Crash Conference, S.A.E., 1968.
4. Gurdjian, E.S., "Recent Advances in the Study of the Mechanisms of Impact Injury of Head," reprint from *Clinical Neurosurgery*, Vol. 19, 1972.
5. Mahajan, B.M., "A Guide for Police Helmets," NBS Report 1975 (in print).
6. Rowbothan, G.F., "Acute Injuries of the Head," Williams and Williams, Baltimore, 1964.
7. Gurdjian, E.S., "Prevention and Mitigation of Head Injuries," reprint from *Clinical Neurosurgery*, Vol. 19, 1972.
8. Synder, R.G., "State-of-the-Art: Human Impact Tolerances," S.A.E. Paper No. 700398, 1970, reprinted in 1972.
9. Hodgson, V.R., Thomas, L.M., and Prasad, P., "Testing the Validity of the Severity Index," Proc. of 14th Stapp Car Crash Conference, S.A.E., 1970.
10. Berger, R.E. and Calvano, N., "Methodology for Choosing Test Parameters to Evaluate Protective Headgear," NBS Report No. NBSIR 78-1547, Nov. 1978.
11. Hodgson, V.R., et. al. "Injury to the Facial Bones," Proc. of 9th Stapp Car Crash Conference, S.A.E., Oct. 1966.
12. *Uniform Building Code*, International Conference of Building Officials, 1976.
13. *One and Two Family Dwelling Code*, Second Edition, 1975.
14. Fattal, S.G., Cattaneo, L.E., Turner, C.E., and Robinson, S.W., *A Model Performance Standard for Guardrails*, National Bureau of Standards Report, NBSIR76-1131, July 1976.
15. Australian Standard Specifications for Playground Equipment for Park, Schools and Domestic Use (Draft Standard for Public Review), Standards Association of Australia, January 1978.
16. *Safety Requirements for Home Playground Equipment Voluntary Product Standard, PS66-75*, National Bureau of Standards, July 1976 (Also published as American National Standards Institute Z304.1-1976, May 1976).
17. *Anthropometry of Infants, Children, and Youths to Age 18 for Product Safety Design*, University of Michigan, May 1977.
18. *The BOCA Basic Building Code, Building Officials and Code Administrators*, International, Inc., 1975.
19. Fattal, S.C. and Cattaneo, L.E., *Investigation of Guardrails for the Protection of Employees from Occupational Hazards*, National Bureau of Standards Report No. NBSIR76-1139, July 1976.
20. *Weight, Height, and Selected Body Dimensions of Adults U.S. 1960-62*, Public Health Service, Department of Health Education and Welfare.
21. CPSC, "Hazard Analysis of Injuries Relating to Playground Equipment" (NIIC-1201-75-M005), March 1975.
22. Roth, H.P. and Burke, D.M., "Head Impact G in Free Fall on Various Surfaces and Padding Materials," unpublished work submitted by D.M. Burke to CPSC, April 1975.
23. Thomas, L.M., Hodgson, V.R., and Gurdjian, E.S., "Skull Fracture and Management of Open Head Injury," *Neurological Surgery*, Vol. 2, W.B. Saunders Co., Phila., 1973.
24. Gurdjian, E.S., and Schuwan, H.K., "Management of Skull Fracture Involving the Frontal Sinus," *Annals of Surgery*, Vol. 95, 1932.
25. Mahajan, B.M., "Standards for Athletic Helmets - A State-of-the-Art and Recommendations," NBS Report No. NBSIR73-276, April 1974.
26. Gadd, C.W., "Use of a Weighted-Impulse," Proc. 10th Stapp Car Crash Conf., S.A.E., New York, 1966, pp. 164-174.

27. Mohan, D., Bowman, B., Snyder, R.G., and Foust, D.R., "A Biomechanical Analysis of Head Impact Injuries to Children," presented at the Ninth Annual Neuroelectric Society Meeting, December 1977.
28. Draper, N., and Smith, H., *Applied Regression Analysis*, John Wiley and Sons, New York, NY.
29. *Suggested Safety Requirements and Supporting Rationale for Swing Assemblies and Straight Slides*, Product Safety Technology Division, National Bureau of Standards, Memorandum Report to the CPSC, April 1978.
30. *Suggested Safety Guidelines and Supporting Rationale for Public Playground Equipment*, Product Technology Division, National Bureau of Standards, Memorandum Report to the CPSC, August, 1978.
31. *Report on Environmental Conditions that Affect Safety Attributes of Surfacing Materials Placed Under Playground Equipment*, CPSC-ESEP, Rivero, Memorandum Report, July 17, 1978.
32. *Impact Attenuation Performance of Surfaces Installed Under Playground Equipment*, Product Technology Division, National Bureau of Standards, NBSIR 79-1707, February, 1979.
33. *Soil Impact Attenuation Performance: A Field Study*, Product Technology Division, National Bureau of Standards, Memorandum Report to the CPSC, November, 1979.

★ U. S. GOVERNMENT PRINTING OFFICE : 1986 O - 491-120 (52708)

For further information, write:

**U.S. Consumer Product Safety
Commission
Washington, D.C. 20207**

To report a product hazard or a product-related injury, write to the U.S. Consumer Product Safety Commission, Washington, D.C. 20207, or call the toll-free hotline: 800-638-CPSC. A teletypewriter for the deaf is available on the following numbers: National 800-638-8270, Maryland only 800-492-8104.

Regional Office Addresses

MIDWESTERN REGIONAL OFFICE
230 South Dearborn Street, Rm. 2945
Chicago, Illinois 60604
(312) 265-2600

SOUTHEASTERN REGIONAL OFFICE
730 Peachtree Street, N.E., Suite 871
Atlanta, Georgia 30305
(404) 525-2100

NORTHEASTERN REGIONAL OFFICE
6 World Trade Center
Vesey Street, Rm. 301
New York, New York 10048
(212) 764-1000

SOUTHWESTERN REGIONAL OFFICE
100 Commerce Street, Rm. 1010
Dallas, Texas 75201
(214) 767-3200

SOUTHERN REGIONAL OFFICE
555 Market Street, Rm. 211
San Francisco, California 94102
(415) 398-3000

CPSC Resident Posts

Albuquerque, New Mexico
Baltimore, Maryland
Boston, Massachusetts
Bridgeport, Connecticut
Buffalo, New York
Charlotte, North Carolina
Cincinnati, Ohio
Cleveland, Ohio
Denver, Colorado
Detroit, Michigan
Honolulu, Hawaii
Houston, Texas
Indianapolis, Indiana
Kansas City, Missouri
Little Rock, Arkansas
Los Angeles, California
Miami, Florida
Milwaukee, Wisconsin
New Orleans, Louisiana
Orlando, Florida
Philadelphia, Pennsylvania
Phoenix, Arizona
Pittsburgh, Pennsylvania
Portland, Oregon
Rockville, Maryland
San Juan, Puerto Rico
Seattle, Washington
St. Louis, Missouri
St. Paul, Minnesota
Trenton, New Jersey
Tulsa, Oklahoma

This document is in the public domain. It may be reproduced in part or in whole by an individual or organization without permission. If it is reproduced, however, the Commission would appreciate knowing how it is used. Write the U.S. Consumer Product Safety Commission, Office of Information and Public Affairs, Washington, D.C. 20207.

The U.S. Consumer Product Safety Commission (CPSC) is an independent regulatory agency charged with reducing unreasonable risks of injury associated with consumer products. CPSC is headed by five Commissioners appointed by the President with the advice and consent of the Senate.

Appendix N

COMSIS Report on Playground Safety for U. S. Consumer Product Safety Commission

Appendix O

**Draft of Minimum
Playground Standards, in
Response to House Bill 1035,
for Child Care Centers,
Before and After School
Child Care Programs, and
Child Day Care Camps
Serving School Age
Children**



COMMONWEALTH of VIRGINIA

Child Day-care Council

August 5, 1991

MEMORANDUM

TO: Programs Involved with Children
Other Interested Persons

FROM: Peg Spangenthal, Chair

A handwritten signature in cursive script, appearing to read "Peg Spangenthal".

SUBJECT: Proposed Child Care Regulations

House Bill 1035 passed by the 1990 General Assembly Session revised the criteria for subjectivity to child care licensure. Many programs not currently regulated such as nursery schools, child day care camps, governmental sponsors of child day care, and hospital sponsored child care for employees will become newly subject to licensure effective July 1, 1992. The bill retains the licensure exemption for child care centers operated by religious institutions and creates this exemption for the programs that will be newly subject to licensure in July, 1992. In response to this change and other changes in the law, the Child Day-Care Council approved several regulations for public comment.

The regulations approved by the Council are:

- Minimum Standards for Licensed Child Care Centers, Nursery Schools, and Child Day Care Camps Serving Children of Preschool Age or Younger;
- Minimum Standards for Licensed Child Care Centers, Before School and After School Child Care Programs, and Child Day Care Camps Serving School Age Children; and
- General Procedures and Information for Licensure.

These regulations, as well as draft application forms, are attached for your review and comment.

VR 175-09-01 MINIMUM STANDARDS FOR LICENSED CHILD CARE CENTERS, BEFORE SCHOOL AND AFTER SCHOOL CHILD CARE PROGRAMS, AND CHILD DAY CARE CAMPS SERVING SCHOOL AGE CHILDREN

- §4.31 Where a fall zone exists, the resilient surfacing shall be:
1. Immediately under equipment;
 2. Extended to a minimum of six feet from the perimeter of the equipment;
 3. Extended one additional foot beyond the requirement of 4.31.2 for each foot of equipment height above six feet; and
 4. Extended six feet in both directions of the motion of swings starting from a point 42 inches beyond the seat at its maximum attainable angle.
- §4.32 Fall zones shall be free of all obstacles.
- §4.33 Ground footings or supports shall be in-ground below ground level.
- §4.34 Equipment used by children shall:
1. Have no accessible openings that are greater than three and one half inches and less than nine inches; and
 2. Have closed S-hooks when provided; and
 3. Have no protrusions, sharp points, shearing points, or pinch points.
- §4.35 All swing seats shall be made of flexible material except for special swing equipment for a child with a developmental delay.
- §4.36 Sandboxes with bottoms which prevent drainage shall be covered when not in use.

SCHOOL AGE

- §4.37 For school age children, horizontal clearances between swings shall be at least 24 inches.
- §4.38 For school age children, unoccupied swing seats shall be a minimum of 18 inches from the ground.
- §4.39 For school age children, slides and climbing equipment with platforms which are 30 inches or more from the ground shall have guardrails or protective barriers of at least 38 inches to prevent falls.

VR 175-09-01 MINIMUM STANDARDS FOR LICENSED CHILD CARE CENTERS, BEFORE SCHOOL AND AFTER SCHOOL CHILD CARE PROGRAMS, AND CHILD DAY CARE CAMPS SERVING SCHOOL AGE CHILDREN

4. A covered receptacle for soiled bed linens; and

SCHOOL AGE

5. Privacy for changing diapers of school age children.

Article 5. Outdoor Areas

GENERIC

§4.26 Centers may have until July 1, 1994, to meet standards 4.27 through 4.39 if standards 5.11 through 5.20 of the 1989 version of the Minimum Standards for Licensed Child Care Centers are met. Please see Appendix IV for standards 5.11 through 5.20 of the 1989 regulations.

§4.27 The outdoor play area shall provide a minimum of 75 square feet of space per child in the area at any one time.

§4.28 Playgrounds shall be located or designed in a way to protect children from hazardous situations.

§4.29 Resilient surfacing shall be placed under all fixed playground equipment with moving parts or climbing apparatus to create a fall zone.

§4.30 The resilient surfacing areas shall consist of one of the following:

Critical Equipment Heights (in feet) for
Various Types and Depths of Resilient Material

Material	Uncompressed Depth			Compressed Depth
	6 inch	9 inch	12 inch	9 inch
Wood Mulch	7 ft	10 ft	11 ft	10 ft
Double Shredded Bark Mulch	6 ft	10 ft	11 ft	7 ft
Uniform Wood Chips	6 ft	7 ft	>12 ft	6 ft
Fine Sand	5 ft	5 ft	9 ft	5 ft
Coarse Sand	5 ft	5 ft	6 ft	4 ft
Fine Gravel	5 ft	7 ft	10 ft	6 ft
Medium Gravel	5 ft	5 ft	6 ft	5 ft

Article 3. Outdoor Activity Area

- 5.11 Centers shall use a clean, safe outdoor activity area, either adjoining or accessible to the center, which shall provide a minimum of 75 square feet of space per child on the outdoor area at any one time.
- 5.12 Centers licensed for the care of infants and toddlers shall provide at least 25 square feet of unpaved surface per infant/toddler on the outdoor area at any one time. This unpaved surface shall be suitable for crawling infants and for toddlers learning to walk. This space may be counted as part of the 75 square feet required in 5.11.
- NOTE: Space covered by sand in sand boxes or play areas may be counted toward the 25 square feet of unpaved surface.
- 5.13 Asphalt, concrete, or similar hard surface shall not be the only outdoor surface.
- 5.14 Where natural shade is not available, the center shall make provision for creating a shaded area or areas.
- 5.15 Resilient surfaces shall be placed under slides and climbing equipment more than four feet high and all swing sets to help absorb the shock if a child falls off the equipment. Resilient surfaces include, but are not limited to, sand, mulch, pea gravel, shredded tires, and rubberized surfaces.
- 5.16 Where swings are provided, they shall have soft or flexible seats such as, but not limited to, nylon or rubber belting rather than hard wooden, metal, or fiberglass seats.
- 5.17 Ground supports for slides, swing sets, and climbing equipment shall be covered with material(s) which would protect children from injury.
- 5.18 Where slides are provided, the lower ends shall be no more than 15 inches above the ground.
- 5.19 For outdoor activity areas used by toddlers and preschool children, the climbing portion of slides and climbing equipment shall not be more than seven feet high.
- 5.20 Outside sand in self-contained boxes with bottoms which prevent drainage shall be covered when not in use.

Appendix P

Child Care and Development Block Grant Fact Sheet

Child Care and Development Block Grant Fact Sheet

- On September 7, 1991 Virginia will receive \$12.8 million Child Care and Development Block Grant funding.
- These funds will be distributed by the Council on Child Day Care and Early Childhood Programs, the state agency mandated to coordinate child day care services in the Commonwealth.
- The Department of Education applied for, and was granted \$2.4 million of these funds (from the Council) to support the development and operation of programs for at-risk four year olds and for school age children who need supervision before and/or after school, and during holidays and the summer.
- Beginning on September 1, 1991, the Department of Education will issue Requests for Proposals (RFP's) to local school divisions. Program initiatives to be funded are:

Chapter I - Pre-Kindergarten Projects Expansion

Ten grants of approximately \$35,000 each will be made to school divisions/schools that are currently operating Chapter I - Pre-Kindergarten part-day programs. The new funding will be wrapped around Chapter I funds to provide a full day, full year program for children in the Pre-Kindergarten projects.

New School-Based Programs for At-Risk Four-Year-Olds

Ten grants of approximately \$60,000 each will be awarded to school divisions/schools to operate new four-year-old groups. Criteria for funding include: collaboration with other agencies (health, mental health, social services) to provide comprehensive services; developmentally appropriate curriculum, and a full day, full year schedule.

Community-Based Programs for At-Risk Four-Year-Olds

A minimum of ten grants (base - \$60,000 each) will be awarded to private and/or public alliances to conduct comprehensive full day, full year early childhood programs for at-risk four-year-olds. Criteria for funding include: requirement of a formal mechanism for accounting, and disbursement of funds; evidence of a planned collaborative effort, and assurance that developmentally appropriate programs will be offered.

Appendix Q

Letters to Organizations



COMMONWEALTH of VIRGINIA

DEPARTMENT OF EDUCATION

P.O. BOX 6-0

RICHMOND 23216-2060

September 6, 1991

Mr. Donald Lacey, Executive Director
Virginia Association of Elementary School Principals
3212 Cutshaw Ave., Suite 208
Richmond, Virginia 23230

Dear Mr. Lacey:

The Virginia Department of Education has formed a team of curriculum specialists to research several issues associated with the safety of playgrounds and playground equipment in the Commonwealth's public schools. One of the objectives of our study is to determine what safety standards various groups have either adopted as recommendations or desire to have established as safety standards.

Our question to you concerns whether the VAESP has developed or adopted recommendations or standards which you perceive will meet the goals of increased playground safety. At your earliest convenience, would you please send us a copy or summary of any guidelines you have developed or adopted concerning this issue.

If you have not taken a position at this point on safety standards for school playgrounds or playground equipment, please let us know any opinion you have in regard to the need for such guidelines, standards, or regulations. If you would like to discuss this issue with me, please contact me. My telephone number is 225-2652.

I thank you in advance for any assistance you may be able to give the Department in this important project.

Sincerely,

Valerie Barrett

Valerie Barrett
Associate Specialist
(Project Team Leader)



COMMONWEALTH of VIRGINIA

DEPARTMENT OF EDUCATION

P.O. BOX 6-Q

RICHMOND 23216-2060

September 6, 1991

Mr. Richard Martin, President
Virginia Congress of Parents and Teachers
3810 Augusta Ave.
Richmond, Virginia 23230

Dear Mr. Martin:

The Virginia Department of Education has formed a team of curriculum specialists to research several issues associated with the safety of playgrounds and playground equipment in the Commonwealth's public schools. One of the objectives of our study is to determine what safety standards various groups have either adopted as recommendations or desire to have established as safety standards.

Our question to you concerns whether the Congress of Parents and Teachers has developed or adopted recommendations or standards which you perceive will meet the goals of increased playground safety. At your earliest convenience, would you please send us a copy or summary of any guidelines you have developed or adopted concerning this issue.

If you have not taken a position at this point on safety standards for school playgrounds or playground equipment, please let us know any opinion you have in regard to the need for such guidelines, standards, or regulations. If you would like to discuss this issue with me, please contact me. My telephone number is 225-2652.

I thank you in advance for any assistance you may be able to give the Department in this important project.

Sincerely,

Valerie Barrett
Associate Specialist
(Project Team Leader)



COMMONWEALTH of VIRGINIA

DEPARTMENT OF EDUCATION

P.O. BOX 6-Q

RICHMOND 23216-2060

September 6, 1991

Virginia Z. Kucera, Project Manager
Division of Child Care & Adolescent Health
American Academy of Pediatrics
141 Northwest Point Blvd.
P. O. Box 927
Elk Grove Village, Illinois 60009-0927

Dear Ms. Kucera:

The Virginia Department of Education has formed a team of curriculum specialists to research several issues associated with the safety of playgrounds and playground equipment in the Commonwealth's public schools. One of the objectives of our study is to determine what safety standards various groups have either adopted as recommendations or desire to have established as safety standards.

Our question to you concerns whether the American Academy of Pediatrics has developed or adopted recommendations or standards which you perceive will meet the goals of increased playground safety. At your earliest convenience, would you please send us a copy or summary of any guidelines you have developed or adopted concerning this issue.

If you have not taken a position at this point on safety standards for school playgrounds or playground equipment, please let us know any opinion you have in regard to the need for such guidelines, standards, or regulations. If you would like to discuss this issue with me, please contact me. My telephone number is (804) 225-2652.

I thank you in advance for any assistance you may be able to give the Department in this important project.

Sincerely,

Valerie Barrett
Associate Specialist
(Project Team Leader)

Appendix R

Safety First Checklist - The
Site Inspection System for
Play Equipment, Produced
by the National Safety
Council